

Fall 1-31-2004

Modeling and analysis of hospital facility layout problem

Amol Shrikrishna Padgaonkar
New Jersey Institute of Technology

Follow this and additional works at: <https://digitalcommons.njit.edu/theses>



Part of the [Industrial Engineering Commons](#)

Recommended Citation

Padgaonkar, Amol Shrikrishna, "Modeling and analysis of hospital facility layout problem" (2004). *Theses*. 528.

<https://digitalcommons.njit.edu/theses/528>

This Thesis is brought to you for free and open access by the Electronic Theses and Dissertations at Digital Commons @ NJIT. It has been accepted for inclusion in Theses by an authorized administrator of Digital Commons @ NJIT. For more information, please contact digitalcommons@njit.edu.

Copyright Warning & Restrictions

The copyright law of the United States (Title 17, United States Code) governs the making of photocopies or other reproductions of copyrighted material.

Under certain conditions specified in the law, libraries and archives are authorized to furnish a photocopy or other reproduction. One of these specified conditions is that the photocopy or reproduction is not to be “used for any purpose other than private study, scholarship, or research.” If a user makes a request for, or later uses, a photocopy or reproduction for purposes in excess of “fair use” that user may be liable for copyright infringement,

This institution reserves the right to refuse to accept a copying order if, in its judgment, fulfillment of the order would involve violation of copyright law.

Please Note: The author retains the copyright while the New Jersey Institute of Technology reserves the right to distribute this thesis or dissertation

Printing note: If you do not wish to print this page, then select “Pages from: first page # to: last page #” on the print dialog screen



The Van Houten library has removed some of the personal information and all signatures from the approval page and biographical sketches of theses and dissertations in order to protect the identity of NJIT graduates and faculty.

ABSTRACT

MODELING AND ANALYSIS OF THE HOSPITAL FACILITY LAYOUT PROBLEM

**by
Amol Shrikrishna Padgaonkar**

The optimal solution to any facility layout problem is an important aspect and a major concern as it involves significant material handling and transportation cost. The objective is to arrange the departments within the predefined facility boundaries in the way that the interaction between the functions is efficient and the overall movement cost is minimized. While facility layout problems have traditionally focused on manufacturing facilities, there has been little work on analyzing layouts for hospitals. The thesis focuses on hospital facility layout problems (HLP) to (i) minimize the movements of patients and (ii) minimize the movements of accompanying resources such as doctors, nurses, equipment and paramedical staff. The thesis consists of two sections. In the first section, a model for the multi-floor layout problem is presented based on the minimization of movement cost. The model has travel frequency or number of trips, trip difficulty rating, baseline travel cost and distance as parameters for determining the movement cost. In the second section, some additional parameters and constraints are imposed on the model and it is simulated using Microsoft Excel. Simulations are also run to study the effect of different proposed strategies on movement cost. These proposed strategies show a reduction in movement cost from the sample layout strategy in section one. A representative example is used to illustrate the applicability of the proposed formulation.

**MODELING AND ANALYSIS OF THE HOSPITAL
FACILITY LAYOUT PROBLEM**

by
Amol Shrikrishna Padgaonkar

**A Thesis
Submitted to the Faculty of
New Jersey Institute of Technology
In Partial Fulfillment of the Requirements for the Degree of
Master of Science in Industrial Engineering**

Department of Industrial and Manufacturing Engineering

January 2004

APPROVAL PAGE

**MODELING AND ANALYSIS OF THE HOSPITAL
FACILITY LAYOUT PROBLEM**

Amol Shrikrishna Padgaonkar

Dr. Sanchoy Das
Professor of Industrial and Manufacturing Engineering, NJIT

Date

Dr. Athanassios Bladikas
Associate Professor and Chairperson of Industrial and Manufacturing Engineering, NJIT

Date

Dr. Layek Abdel-Malek
Professor of Industrial and Manufacturing Engineering, NJIT

Date

Blank Page

BIOGRAPHICAL SKETCH

Author: Amol Shrikrishna Padgaonkar

Degree: Master of Science

Date: January 2004

Undergraduate and Graduate Education:

- Master of Science in Industrial Engineering,
New Jersey Institute of Technology, Newark, NJ, 2004
- Bachelor of Engineering in Mechanical Engineering,
K.J.Somaiya College of Engineering, Mumbai, India, 2001

Major: Industrial Engineering

This thesis is dedicated to my beloved parents.

ACKNOWLEDGEMENT

I take this opportunity to express my deep gratitude towards my advisor, Dr. Sanchoy Das, for his unstinting support, which brought this thesis to its logical conclusion. His guidance made my journey easy in an area, which I had never ventured before.

I also want to thank Saint Michael's Medical Center, Newark for permitting me to incorporate data related to my thesis.

Also thanks to the Department of Industrial and Manufacturing Engineering for allowing me to use their facilities.

Last but not the least, I thank Dr. Athanassios Bladikas and Dr. Layek Abdel-Malek for taking time out of their busy schedule and going through my thesis in painstaking detail.

TABLE OF CONTENTS

Chapter	Page
1 INTRODUCTION	1
1.1 Introduction to Hospital Facility Layout and Design	1
1.2 Classes of Facility Layout Problems	5
1.3 Types of Facility Layouts	6
1.3.1 Fixed Location Department Layout	6
1.3.2 Production Line Product Department Layout.....	7
1.3.3 Group Layout	8
1.3.4 Functional or Process Department Layout	9
1.4 Literature Review	10
1.5 Research Problem	15
1.6 Research Objective	16
2 MODELING THE HOSPITAL FACILITY LAYOUT PROBLEM	18
2.1 Necessity for Hospital Layout Design	18
2.2 Fundamental Considerations in Designing Facility Layout for Hospitals	21
2.2.1 Movement Costs	21
2.2.2 Vertical Motion for Multi-floor Layouts	22
2.2.3 Modeling Entities	24
2.3 Advantages in Designing Facility Layouts for Hospitals	27

TABLE OF CONTENTS
(Continued)

Chapter	Page
3 ANALYSIS OF THE LAYOUT	28
3.1 Introduction	28
3.2 Methodology for Developing Hospital Facility Layout	28
3.3 Representation of the Hospital Facility Layout	29
3.4 Attributes for Deriving the Movement Cost	33
3.4.1 Distance Attribute	33
3.4.2 Travel Frequency Attribute	34
3.4.3 Trip Difficulty Rating	35
3.4.4 Baseline Travel Cost	37
3.5 Generation of the Cost Function	38
3.6 Illustrative Example	41
4 STRATEGIES FOR OPTIMAL LAYOUT	47
4.1 Facility Layout Design with Area Considerations and Elevator Closeness Index	47
4.2 Facility Layout Design Using Area Considerations, E.C.I and Relationship Matrix	52
4.3 Facility Layout Design by Splitting Departments onto Different Floors	59
5 SUMMARY	64
APPENDIX CALCULATION OF OPTIMAL NUMBER OF FLOORS	68
REFERENCES	70

LIST OF FIGURES

Figure		Page
1.1	Flowchart for layout planning procedure	2
1.2	Space relationship diagram	4
1.3	Alternative layouts	4
1.4	Fixed location department layout	6
1.5	Production line product department layout	7
1.6	Group layout	8
1.7	Functional or process department layout	9
2.1	Hospital departments	26
3.1	Flowchart for layout design	29
3.2	Floor dimensions for the hospital building	32
3.3	Sample floor1 layout	43
3.4	Sample floor2 layout	44
3.5	Sample floor3 layout	44
3.6	Sample floor4 layout	45
3.7	Sample floor5 layout	45
3.8	Sample floor6 layout	46
3.9	Sample floor7 layout	46
4.1	Floor1 layout for simulation strategy1	49
4.2	Floor2 layout for simulation strategy1	49
4.3	Floor3 layout for simulation strategy1	50
4.4	Floor4 layout for simulation strategy1	50

LIST OF FIGURES
(Continued)

Figure	Page
4.5 Floor5 layout for simulation strategy1	51
4.6 Floor6 layout for simulation strategy1	51
4.7 Floor7 layout for simulation strategy1	52
4.8 Floor1 layout for simulation strategy2	56
4.9 Floor2 layout for simulation strategy2	56
4.10 Floor3 layout for simulation strategy2	57
4.11 Floor4 layout for simulation strategy2	57
4.12 Floor5 layout for simulation strategy2	58
4.13 Floor6 layout for simulation strategy2	58
4.14 Floor1 layout for simulation strategy3	61
4.15 Floor2 layout for simulation strategy3	61
4.16 Floor3 layout for simulation strategy3	62
4.17 Floor4 layout for simulation strategy3	62
4.18 Floor5 layout for simulation strategy3	63
4.19 Floor6 layout for simulation strategy3	63
5.1 Effect of layout strategies on movement cost	64

LIST OF TABLES

Table		Page
3.1	Hospital Departments and Area Allocation	31
3.2	Distance Matrix	34
3.3	Travel Frequency Matrix	35
3.4	Trip Difficulty Rating Scale	36
3.5	Trip Difficulty Matrix	37
3.6	Baseline Travel Cost Factor	38
3.7	Baseline Travel Cost x Trip Difficulty Rating Matrix	39
3.8	Movement Cost Matrix	40
3.9	Experimental Results from Sample Layout	42
4.1	Simulation Results for Layout Strategy1	48
4.2	Relationship Value Chart	54
4.3	Relationship Matrix	54
4.4	Simulation Results for Layout Strategy2	55
4.5	Simulation Results for Layout Strategy3	60
5.1	Movement Cost Variation Analysis	65

CHAPTER 1

INTRODUCTION

1.1 Introduction to Hospital Facility Layout and Design

The fundamentals, tools and procedures for modeling a hospital facility layout problem are similar to other types of manufacturing and non-manufacturing applications. The general steps followed for designing layouts for hospitals are as follows [1]:

- Define or redefine the main objective of the hospital layout.
- Identify the primary and secondary activities to be performed in achieving the objective.
- Determine the relationships among the departments.
- Determine the spatial requirements for the departments.
- Generate alternative facility layouts.
- Evaluate alternative facility layouts.
- Select a facility layout.
- Implement, maintain and adapt the facility layout.

The layout planning steps for facility layout and design of hospitals are diagrammatically represented with the help of a flowchart in Figure 1.1 [1].

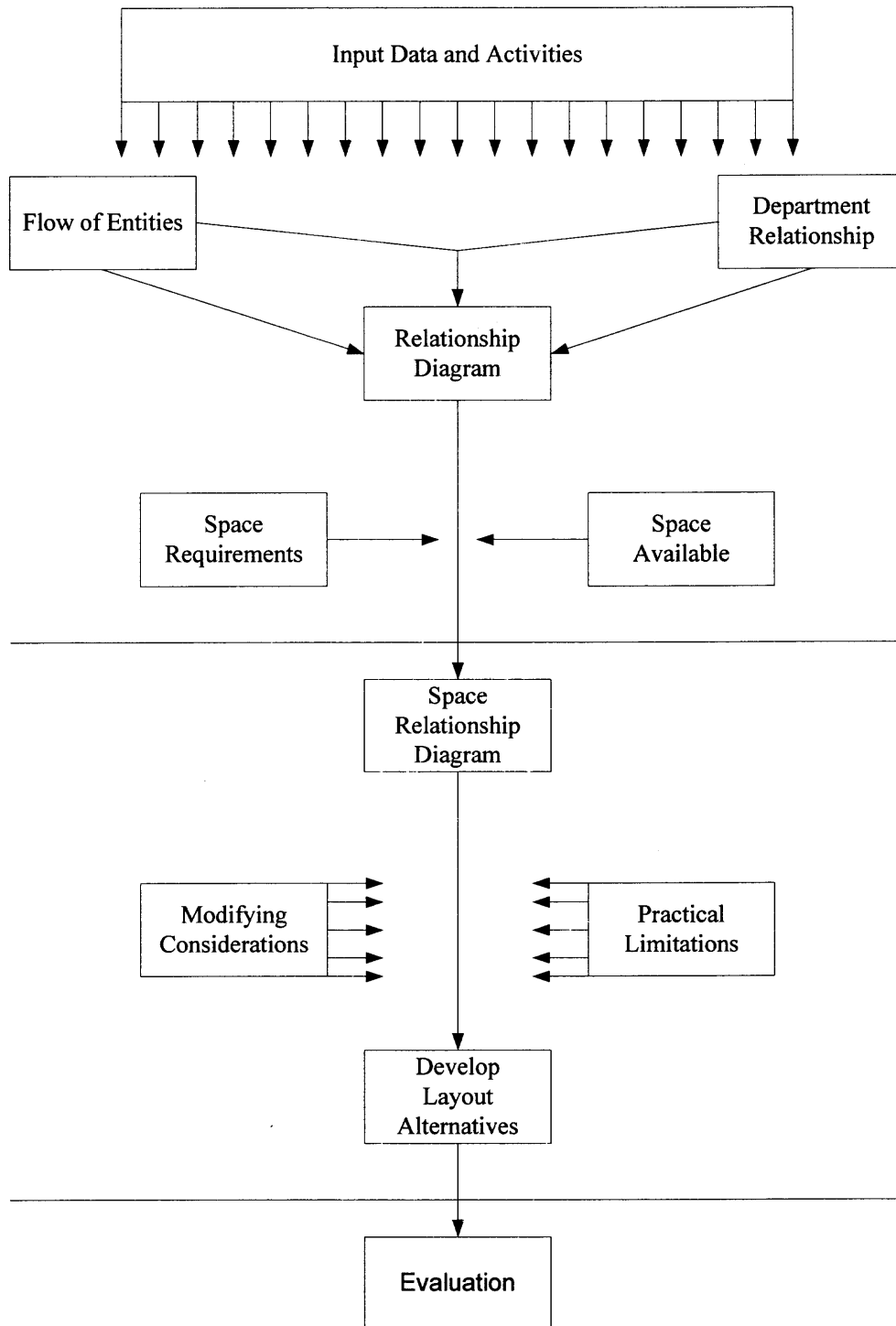

Figure 1.1 Flowchart for layout planning procedure [1].

The first step in the facility layout design involves creating an entity flow and department relationship chart from the given input data and by understanding the roles and relationships among departments. The entity flow chart involves movement of patients and the associated human resources providing service to patients. The relationship chart shows the interactions among departments.

The next step involves determining the amount of space required for each department in the hospital. This is facilitated by the area requirements sheet for each department. The space relationship diagram is then created after space assignments are made. Figure 1.2 represents the space relationship diagram [1]. The figures in the rectangular boxes indicate the department number and the area of the respective department, and lines indicate the relationship value between the departments. The hard solid lines indicate that the relationship is absolutely necessary, light solid lines indicate especially important relationship, dashed lines indicate that the relationship is important (ordinary closeness relationship), whereas dotted lines indicate that the relationship is unimportant or not desirable.

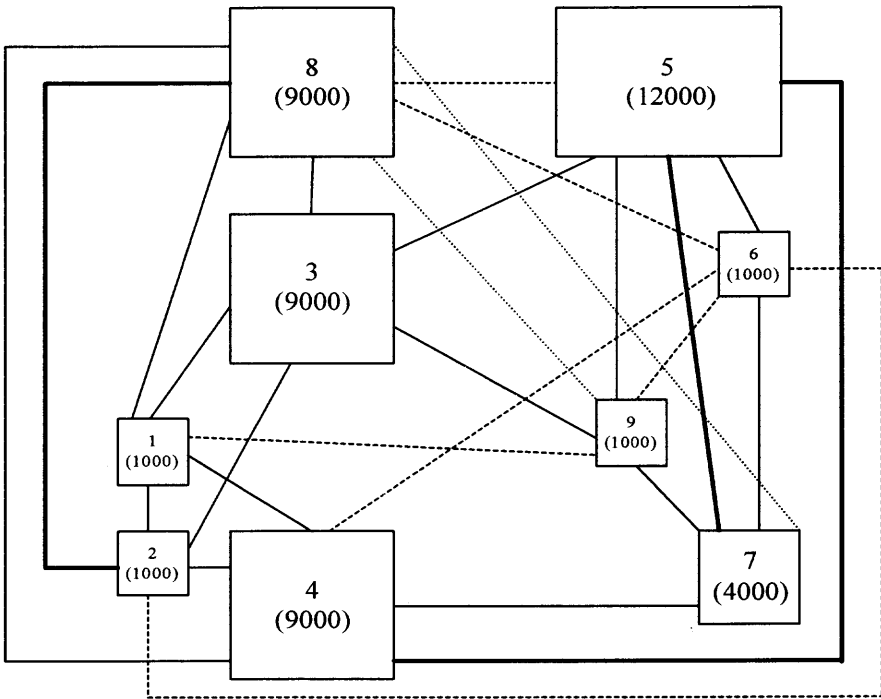

Figure 1.2 Space relationship diagram [1].

The final step involves generating and evaluating a number of layout alternatives based on the modifying considerations and practical constraints. The preferred alternative is chosen from among the alternatives, which satisfy the layout objective. Figure 1.3 represents alternative layouts for the layout represented in Figure 1.2 [1].

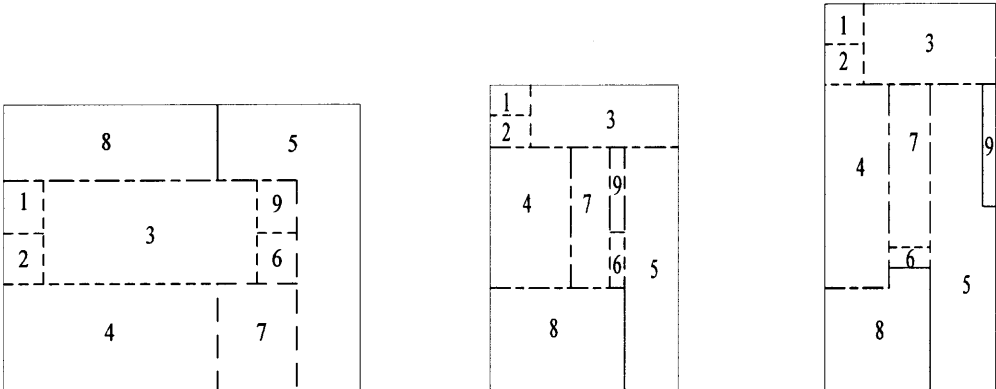

Figure 1.3 Alternative layouts [1].

1.2 Classes of Facility Layout Problems

Hospital facility layout problems can be typically divided into the following four categories [2]:

- *Minor changes in the existing layout*

In most industrial and service plants minor changes in layout rearrangements are made for several reasons. These layout changes require minimal planning and few human resources to develop a workable solution. Most facility layout problems fall into this category.

- *Rearrangement of existing layout*

The problem of rearrangement of existing departments occurs when there are frequent product resource design changes. There are methods and procedures to implement department rearrangements. Whether to abandon obsolete processes and methods is an issue that arises when department rearrangement is considered.

- *Relocating into existing facilities*

The movement of existing facilities to a new building or a new location is a much more complex procedure. The facility layout is generated using methods and processes that will minimize the expense and avoid obsolescence in the future.

- *Building a new plant*

The building of a new plant requires generating a detailed plan for auxiliary areas necessary to make the plant a complete and integrated operation. The detailed plan enclosing the facilities into the building is done later.

1.3 Types of Facility Layouts

Any type of facility layout problem, whether it is a manufacturing unit or service organization as a hospital, is generated using four standard types of layouts.

1.3.1 Fixed Location Department Layout

The fixed location layout differs in concept from the other types of layouts. In this layout the workstations are brought to the department to process the material as opposed to material brought to the workstations in other types of layouts. This layout involves the sequencing and placement of workstations around the material or product. Although this layout is used for large, bulky products it is not so limited in application. For example, in assembling computer systems, the materials, subassemblies, housings, peripherals and components are brought to system integration and test workstations and the finished product is assembled and tested at that location. Figure 1.4 represents a fixed location department layout [1]. In the figure below, A, C, D, G, H, Z represent the workstations where operations are performed on the materials or entities. The arrows specify the flow of materials or entities.

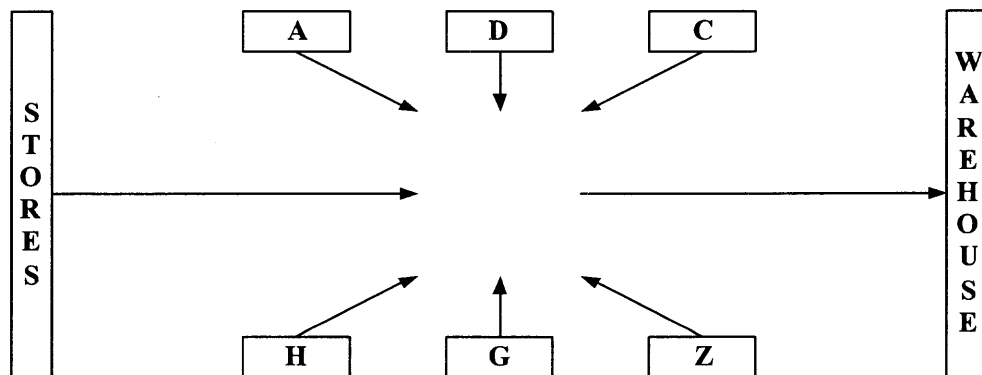

Figure 1.4 Fixed location department layout [1].

1.3.2 Production Line Product Department Layout

The production line department layout is based on the processing sequence of the parts being produced on the line. The flow of materials is directly from one workstation to the next adjacent workstation. Nice-well planned flow paths generally result in a high-volume environment [1]. Figure 1.5 represents a production line product department layout. In the figure below, A, B, C, D, E, F, Z represent the workstations where operations are performed on the materials or entities. The arrows specify the flow of materials or entities.

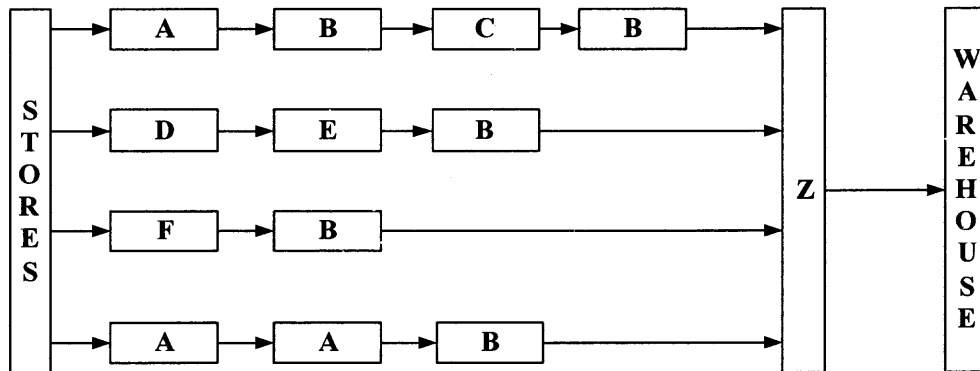

Figure 1.5 Production line product department layout [1].

1.3.3 Group Layout

This layout is based on grouping of parts to form product families. Non identical parts are grouped into families based on processing sequences, shapes, material composition, tooling requirements, handling/storage/control requirements etc. The processing equipment required is grouped together and placed in a cell. The resulting layout has a high degree of intradepartmental flow and little interdepartmental flow. It is also referred to as product family department layout [1]. Figure 1.6 represents this type of layout. In the figure below, A, B, C, D, F, G, H, Z represent the workstations where operations are performed on the materials or entities. The arrows specify the flow of materials or entities.

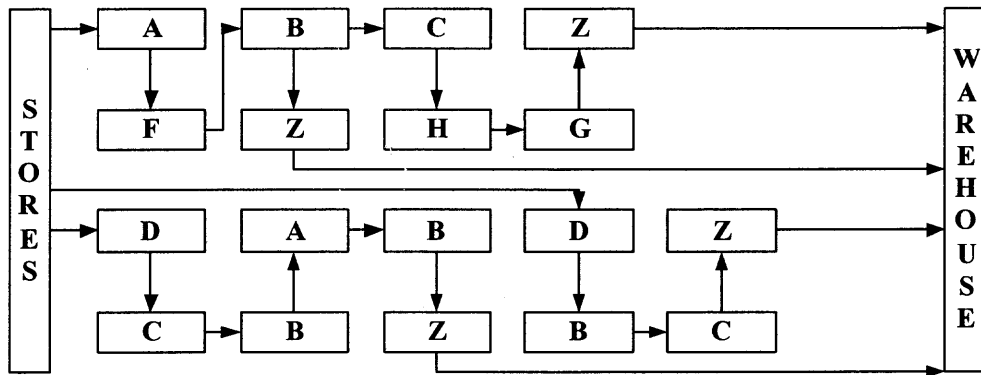

Figure 1.6 Group layout [1].

1.3.4 Functional or Process Department layout

Figure 1.7 represents the functional or process department layout. The layout for a process department is obtained by aggregating identical processes together and placing individual process departments relative to one another based on the flow between departments. In this type of layout, there exists high degree of interdepartmental flow and little intradepartmental flow. This type of layout is used when volume of activity for individual parts or groups of parts is not sufficient to justify a product layout or group layout [1]. In the figure below, A, B, C, F, G, H, Z represent the workstations where operations are performed on the materials or entities. The arrows specify the flow of materials or entities.

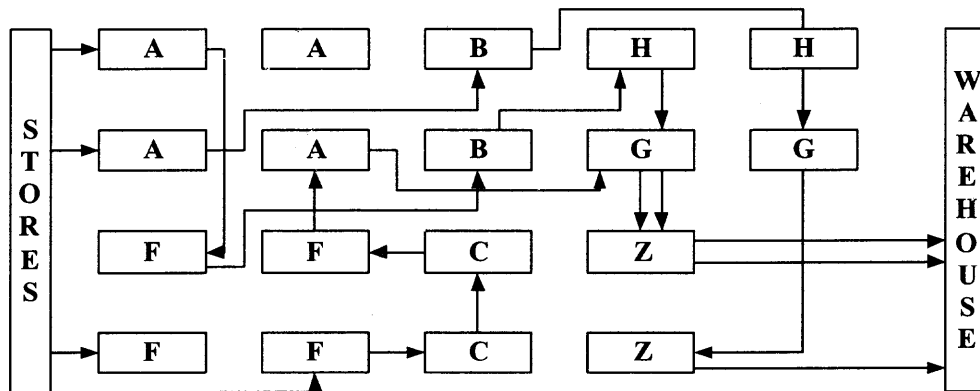

Figure 1.7 Functional or process department layout [1].

1.4 Literature Review

The facility layout problem has gained importance due to significant contributions from Francis and White [3] and Mecklenburg [4]. Kusiak and Heragu [5] and Meller and Gau [6] who reported on many research studies in their publications. All facility layout problems are categorized either as single floor or multi floor layout problems. The single floor layout is more common than the multi floor layout problem.

Any type of facility layout problem, whether it is single or multi-floor layout is solved using four types of solution approaches:

Quadratic Assignment Problem (QAP)

The Quadratic Assignment Problem is a special case of the facility layout problem. It assumes equal areas for each department or equipment items as well as fixed and known locations [7]. It was first introduced by Koopmans and Beckham [8] and later applied to a wide range of applications by Meller and Gau [6]. Different types of solutions were reported from Branch-and-Bound algorithms [9, 10], tabu search [11] and genetic [12, 13] as well as hybrid algorithms [14]

Graph-Theoretic

In a graph-theoretic approach the departments in the layout are assigned a node in the network wherein areas of departments are neglected at the start. The graph is generated with vertices representing the facilities and edges representing the desired adjacencies. The drawing of floor plans using the prevailing constraints is later achieved. [7, 15]. Graph-theoretic approaches claim unequal area problems can be solved to optimality.

Heuristics

Different types of Heuristic approaches have been developed, which are quite effective in solving facility layout problems. They appear not only as solution algorithms but also as model approaches, which try to exploit the layout problem characteristics. The main drawbacks of these approaches are that no optimum solution can be guaranteed, however they are efficient in solving several layout problems [7].

Mixed-Integer Programming

Mixed-Integer Programming is a new approach, which uses a distance-based objective for facility layout [16]. The facility layout problem for departments with equal and unequal areas [18] can be solved as a mixed-integer program by specifying the department orientation, whether it is horizontal or vertical [17]. An optimal solution can be obtained using this approach. A mathematical model was developed for the design of efficient generic industrial layouts where a simultaneous solution of the block and detailed layout problem is considered [7].

Multi floor layout problems are gaining importance, though these layouts are not as common as single floor layouts. The solution to multi-floor layout problem is generated using two approaches. The first is a single stage algorithm starting with an initial feasible solution, which in turn is improved using exchange heuristics. The second is solved using two stages; a partitioning stage wherein the initial problem is divided and a solution to each sub-problem is generated separately. The separate solutions are aggregated at the end.

An approach to the multi-floor facility layout problem is to set it up as a transportation model [19]. In this, the facilities are paired and assigned a priority value

based on the travel frequency between them. A distance matrix is calculated by forming location pairs, with the vertical distances arbitrarily given twice the weights of the horizontal distances. These two matrices determine the cost matrix and the optimal layout is determined as the one, which minimizes total cost.

The three-dimensional problem [20] is divided into horizontal and vertical problems in which a department sequence is generated and is partitioned into subsets based on the number of department that can be accommodated on each floor. These subsets are then assigned to each floor. This approach however does not consider individual interaction between departments, but only between subsets.

The CRAFT-3D heuristics [21] use an improvement strategy over CRAFT to determine solutions that minimize the horizontal and vertical costs. The SPACECRAFT heuristic [22] is similar to CRAFT-3D [21]; however it incorporates non-linear costs by involving waiting times. SPACECRAFT however produces irregular shapes for departments and the ultimate solution is locally optimal.

A space planning system [23] was developed that considers fixed, interactive and moving costs. It uses a construction algorithm, which uses probability theory for determining the effect of assignments. This algorithm is then followed by an improvement heuristic. This system ensures that irregular shapes are not generated. The four-step construction approach [24] was derived for multi floor facility layout problems. In the first step, a partitioning algorithm partitions department into sets based on maximal intra-set interaction and minimal inter-set interaction. The second step assigns each of the sets to one of the floors considering inter-floor travel times. Assuming only one elevator is used for vertical motion; an adjacency graph representing the relative department

location is constructed for each floor. A tetrahedron approach is used to generate a maximal planar adjacency graph. The final step of the algorithm constructs a block plan from the adjacency graph.

A k-median heuristic [25] similar in idea to the four-step construction approach was proposed, which partitions departments into distinct groups and each group is then assigned to floors. Another heuristic obtains the layout of each floor. The layout solution is improved by an exchange algorithm, which exchanges adjacent departments located on the same floor. This method is applied to departments having equal area; however it can be modified for unequal area departments.

A generalized network-partitioning scheme [26] breaks a multi-floor layout problem into m-planar layout problems. A network represents the department, the weight on the department represents space requirements and the arc between nodes measures the interaction between the departments. The graphs are broken into m sub graphs using a tree-partitioning algorithm. The total weight does not exceed the area of a particular floor. The placement is facilitated using a QAP formulation solved by the construction algorithm. If more departments have to be placed, the method also looks at future scenarios using the greedy approach. However, this method does not account for the cost of vertical movement and rearrangement is not possible.

Software called BLOCPLAN [27] was developed, which first asks to manually place the departments onto the floors, or places there automatically based on the areas of the departments. Once departments are placed onto the floors, each problem is treated as a single floor layout problem and is solved using improvement algorithms. This software is useful in solving single and multi-floor layout problems.

Single stage heuristic algorithms MULTIPLE [28] and SABLE [29] provide effective solutions by incorporating costs and constraints prevalent to multi floor layout problems. These algorithms use the concept of space-filling curves (SFCs) to develop layouts. The layout is generated as a grid of squares and the space-filling curve moves along the squares. A two-stage algorithm [30] similar to MULTIPLE and SABLE was proposed, but results were not significantly improved in comparison with the single-stage algorithm.

A genetic algorithm based heuristic MULTI-HOPE [31] is an extension to MULTIPLE and provides better solutions to block layout problems than the previous simulated algorithm based heuristics.

A two stage heuristic [32] for generating multi-floor layouts was proposed. In the first stage, a layout with minimal inter-floor flow is generated which is then improved considering intra/inter floor flow in the second stage using a tabu search.

The hospital facility layout problem was solved considering the problem to be the Koopmans-Beckmann variant of QAP [33]. They proposed a heuristic, which resulted in determining the optimal solution to the hospital layout problem.

A framework to find competitive solutions for the facility layout problem was presented [34]. The framework is based on the combination of two mathematical models. The first model finds good starting points for an iterative algorithm used to solve the second model. The second model is an exact formulation of the facility layout problem as a non-convex mathematical program with equilibrium constraints (MPEC).

Software packages such as CRAFT (Computerized Relative Allocation of Facilities Technique) [35], SDPIM (Steepest Descent Pairwise Interchange Method) by

STORM software, GRASP (Greedy Randomized Adaptive Search Procedure) [36] have been developed for solving big and complex facility layout problems.

1.5 Research Problem

The hospital facility layout problem has received less attention in the literature compared to manufacturing facilities, for which significant research has been done and various methods have been developed for generating efficient facility layouts due to the following reasons [1]:

- The volume and the type of patients to be treated are not controlled by the hospital.
- The physical condition of the patient affects their needs and the demands considerably.
- The facility should be adaptable to the continually changing methods of caring, nursing and treating patients.

Traditionally, hospital facility layouts were not based on the requirements and objectives of a particular facility been planned, but using certain predefined standards. The design of facility layouts by only using these standards and not analyzing the essential requirements results in inefficiency and ineffectiveness. Moreover, factors such as current and future population of the service area, the composition and medical needs of the population, the status and organization of the nearby hospitals and quality and availability of current medical services also affect the layout design.

The most important considerations in hospital design are [1]:

- To minimize the distance between patient care rooms and the nursing units.
- To facilitate easy access and non-overlapping flow paths for various types of patients, employees and supplies.

- To facilitate patient movements in the vertical direction to different floors.
- To make appropriate use of available land.
- To provide for future expansion, depending on the forecasted growth in population.

1.6 Research Objective

The recent trends in maintaining and improving the design of industrial plants gave industrial engineers tools to analyze new demand and create systems to help solve these problems. The annual expenditure in the United States for construction and modification of facilities is more than \$500 billion [37]. Effective planning of facilities would result in the reduction in the overall cost by about 10 to 30 percent [37].

In the United States, the necessity to develop an efficient multi-floor facility layout has increased since firms consider renovating older buildings to save money. The cost of renovating an older building is about $1/10^{\text{th}}$ per square foot than building a new one. Statistics from the past three decades show that less attention is paid to the multi-floor facility layout problem compared to single floor layout. However, significant contributions have been made in developing tools and techniques, which would minimize the movement cost [32].

The objective is to develop a multi-floor facility layout for hospitals to minimize the movement cost of patients and accompanying resources such as doctors, medical, and non-medical staff. The movement cost is directly proportional to travel frequency and distance between functions. The reduction of travel frequency is comparatively difficult because it is a function of medical and regulatory requirements. Thus, facility layout planning focuses on the distance attribute to reduce the movement cost. An optimal

facility layout problem seeks the best possible arrangement of departments, within the predefined area, which results in distance reduction between departments having close relation to each other. A model for optimal placement of facilities at minimal cost is developed. Various alternative layouts are also developed from the proposed strategies and the best possible one is chosen.

CHAPTER 2

MODELING THE HOSPITAL LAYOUT PROBLEM

2.1 Necessity for Hospital Layout Design

The need to provide primary and specialty services in a cost effective manner, while making quality of patient care more valuable is a primary issue for hospitals. The productivity of a hospital is enhanced mainly by the way the facilities are placed, although training and work methods, instrument speed and materials management are some of the important factors improving the performance of different health care delivery processes. The design of hospitals requires, in addition to the physical environment, consideration to the way the operations are organized. The key task in generating a master plan for a hospital facility layout requires identifying the tasks and selecting the principles for the physical grouping of these tasks. The objective of hospital facility layout is specified after performing the market analysis, which involves population count, status of nearby hospitals etc. On the basis of market analysis and consultation with the hospital administrative staff, necessary medical services and capacities to be offered are decided upon. Typically, a rule of thumb suggests the requirement of four hospital beds and 35 emergency cases per 1000 population per week [1]. These are used as general requirements for the planned hospital. Some factors such as specialization in a particular type of surgery and policies of handling admissions and outpatients through the emergency room during evening and night shifts have a large effect on the above rules [1]. The optimal facility layout design requires the consideration of issues such as workflow, interaction between the functions and human resources, and walking distance

between the functions. Hospital facility layout design is not based only on designing standards but also on the objectives of the hospital to be designed. However, the layout designer uses the standards as a reference [1].

A hospital can be characterized as a multi-product organization serving many purposes including patient care and monitoring processes. Taking into consideration dependencies between activities would improve the performance of the organization. A cost reduction can be achieved by minimizing travel among entities and logistics.

Transportation of patients in hospitals is done periodically. Service times (time from picking up a patient at the origin and delivering at the destination) add to the complexity of transportation, which is significantly larger than the actual time required for transportation [38]. Patient movements also depend on the physical condition of the patient, which may necessitate a resource to accompany the patient during transportation. Also the movement cost of a patient may be less than, equal to, or greater than the cost of the resource accompanying him. The modeling of facility layouts for hospitals should incorporate the above factors, which drastically affect the movement cost. The facility layout must consider the cost associated with patient movements and secondarily, the movements of the accompanying entities resulting from the patient movements [39].

Hospital programming is influenced by the increase in the number of elderly people who can be ill on a long-term basis, predicted birth rate, and people moving in and out of the area [40]. These factors influence the demand for beds and the size of departments. The continuously increasing demand necessitates planning for the future, which causes the relocation of certain departments not necessary at the present stage, but

to accommodate future conditions. This problem of expansion needs to be addressed in an effective manner [40].

Another important issue associated with the hospital facility layout problem is the availability of space to build a new building or renovate an existing one. More land area is required if departments are to be placed on a single floor. The land area required for multi-storey buildings is smaller. However, multi-storey building layouts are more complex. They have to consider factors such as the optimal number of floors for the placement of all departments, additional vertical transportation cost, etc.

In a hospital, a wide variety of tasks are performed with varying levels of complexity to provide health care to many patient groups, with each group having complex requirements. A complex relationship between hospitals tasks exists, which demands different methods that improve performance and reduce cost.

Thus, the hospital facility layout design should incorporate all essential requirements such as modeling of entities, movement difficulty, motion in the vertical direction, and the arrangement of departments within the predefined area in a way that reduces the distance between departments having high interaction and satisfies the increase in demand. These factors are analyzed with the aim of minimizing the total movement cost.

2.2 Fundamental Considerations in Designing Facility Layout for Hospitals

The fundamental considerations in hospital facility layout design are specified as follows:

2.2.1 Movement Costs

The movement cost in designing facility layouts for hospitals is based on the cost due the following:

Cost associated with movement of travel entities:

The hospital's goal is to provide patient-focused care in an effective way. The primary cost involved is the cost of moving a patient. The large cost associated with moving a patient is primarily dependent on the level of illness of the patient. Also, a patient has a combination of characteristics involving urgency level, need for immediate surgery, uncertainty regarding services required, etc. The patient usually encounters difficulty in movement after any surgery, intense treatments, severe problems, etc. The cost associated with moving a patient is less if the patient can move independently, which is rather rare. A patient is often accompanied by some resource, which increases the movement cost drastically. This drastic increase in movement cost is associated with the difficulty of movement and the cost of an accompanying resource. The degree of difficulty in movement is the main factor increasing the movement cost of patients, which is modeled by assigning an additional weight to the cost function. The cost associated with the accompanying resource is also assigned an additional weight depending upon whether the resource moves independently or carries some equipment.

Cost based on arrangement of departments

The minimization of the Quadratic Assignment Problem (QAP) objective is the basic requirement of the hospital facility layout problems i.e. the sum of Transportation cost times Distance over all pairs of facilities must be minimum. For hospitals, the facilities are departments in a hospital, which need to be placed in cells in an efficient way. The number of cells is usually greater than the number of departments, but it can also be equal to the number of departments in some cases. Dummy departments are added if the number of cells is greater than the number of departments. The placement of departments takes into account the interaction between departments, which depends on the traffic intensity between the two departments. The departments having more interaction are placed closer than the ones having lesser interaction with the aim being the minimization of the distance between them. Area constraints and certain additional constraints may also be imposed during the placement of the departments onto floors. Different methods are applied to solve QAP problems. Due to lack of effective algorithms to solve sizeable problems to optimality, lower bounds are generated on QAP below the objective function value. The QAP is iteratively transformed, thus generating a sequence of lower bounds on the original problem. The hospital facility layout problem is solved as a QAP by assigning departments to cells in a building so that the total movement cost is minimum [33].

2.2.2 Vertical Motion for Multi-floor Layouts

The transportation of people and equipment vertically in hospitals is facilitated using elevators. The objective is to facilitate transportation from one department to another using the least cost path, which depends on the selection of an elevator. The selection is

based on relative cost, capacity of the elevator and location of the elevator with respect to the department. The number of elevators to be used usually depends on the size of the hospital and the traffic intensity. The elevators are accessible based on availability. As travel frequency in hospitals is high, departments having frequent interaction with departments on other floors are placed closer to the elevator to reduce cost. In multi-floor facility layouts, additional costs and constraints prevail. The costs are non-linear because of the waiting times.

The travel time from a department located on one floor to a department on another floor includes:

- The travel time from the starting department to the selected elevator.
- The time to wait for the elevator.
- The time spent in going from one floor to another floor, which depends on the number of intermediate stops.
- Travel time from the elevator to the ending department.

There is an assumption that the cost associated with travel in a horizontal plane over a given distance is constant, which is not true in the case of vertical transportation. Also different devices have different transportation cost which adds to the complexity of the multi-floor layout problems [31, 32].

On the basis of the above considerations, vertical distances are assigned more weight in the calculations than the horizontal distances.

2.2.3 Modeling Entities

The entities in the hospital are divided into travel entities and departments.

Travel Entities

Travel entities are the people actually moving in the hospital. Classifying the travel entities into primary and secondary travel entities facilitates the hospital facility layout problem modeling.

- Primary travel entities

Patients are the primary resources in hospitals. The main focus is on the movement of patients since a hospital facility is designed with the aim of providing the best possible service to patients. The minimization of patient movements is of primary importance, as it results in the minimization of other travel entity movements as well. Minimization of patient movements is possible by reducing the travel distance. This is achieved by placing departments to which patient visits are more frequent closer to the patient wards. Also, using certain portable devices to provide treatment in the ward itself can minimize movements. Typically, portable devices used in hospitals are the phototherapy unit, X-ray unit, anesthesia apparatus, Fluoroscopy unit, ECG machine, etc.

- Secondary travel entities

Doctors, Medical and Non-Medical staff are classified as secondary entities since their movements are dependent on the needs of the primary travel entities. The medical staff includes nurses, nutrition services staff, laboratory and clinical staff, etc. The non-medical staff includes staff at the wards, administration staff, registration and payment staff, etc. The minimization of secondary entity movements is related to

that of primary entities. The main purpose of these entities is to provide service to patients. The movement cost is primarily dependent on how quickly the service is been provided. Due to this reason departments related to secondary resources movement to patient rooms are placed comparatively closer to the patient wards. The movement cost also depends on whether the entity is accompanying a patient for facilitating the movement or carrying any equipment items such as portable devices along with him. The hospital facility layout is modeled by assigning extra weights to incorporate these costs.

Hospital Departments

Hospital departments are fixed or immovable entities. The prime focus while designing hospital facility layouts is the optimal arrangement of these entities, since the proper placement of departments results in the travel entities having to travel shorter distances, thus reducing the movement cost drastically. To achieve efficient placement of the departments, the interaction between departments should be taken into consideration. This depends on the travel frequency between departments. The travel frequency determines the relationship factor. The departments having high traffic between them are placed closer to each other than the ones with less traffic. This adjacency requirement thus increases functionality and efficiency. The facility layout design as is illustrated in this thesis considers a hospital with 38 departments. The list of departments was obtained by visiting the Saint Michael's Medical Center. The departments are listed in Figure 2.1.

i	Department Name	Notation
1	Anesthesia room	AR
2	Birth center	BC
3	Blood bank	Blood
4	Blood testing	BT
5	Cafeteria	Café
6	Cashier's office	Pay
7	Cath lab	CL
8	Cobalt machine lab	CoM/C
9	Computed tomography scan	CT
10	Conference room	CR
11	Doctors room	DR
12	Examination room	ER
13	General ward	GW
14	Hematology lab	HL
15	Inpatient registration	InReg
16	Intensive care unit	ICU
17	Linear accelerator lab	LINAC
18	Mammography lab	M
19	Medical records room	MRR
20	Nurses room	NR
21	Nutrition services	NS
22	Obstetrics and gynecology ward	OGW
23	Operation theatre	OT
24	Orthovoltage lab	OvoIM/C
25	Outpatient registration	OutReg
26	Pharmacy	Phar
27	Planning computer lab	PC
28	Recovery room	RR
29	Rehabilitation center	RehabC
30	Social services	SS
31	Special ward	SW
32	Specialty clinic	SC
33	Surgical equipments room	SeqR
34	Ultrasonography lab	U
35	Waiting room	WR
36	Walk-in-clinic	WIC
37	X-ray lab	X
38	X-ray simulator lab	S

Figure 2.1 Hospital departments.

2.3 Advantages in Designing Facility Layouts for Hospitals

Designing optimal facility layouts for hospitals has tremendous benefits especially on a long-term basis. These advantages are:

- The best possible location of the departments is achieved.
- The forecasting of future demand and capacity requirements can be analyzed with the help of a capacity model.
- The in-depth analysis of the interaction between the departments is obtained, which is useful in predicting the future course of action.
- For micro layouts, major workstations and instruments are placed in optimal work cells similar to macro layouts.
- Equipment clearances, human ergonomics, sample requirements and walking distances are optimized.

CHAPTER 3

ANALYSIS OF THE LAYOUT PROBLEM

3.1 Introduction

The aim of this research is to seek the best possible arrangement of facilities for a hospital building that minimizes the movement cost. A model is generated for the movement cost taking into consideration the different attributes and constraints associated with the hospital. This layout model is simulated using Microsoft Excel to obtain a layout, which reduces the movement cost. The placement of the “n” departments into an optimal number of floors is also determined. An illustrative example is used for the applicability of the formulation considering a 150-bed hospital with 38 departments.

3.2 Methodology for Developing Hospital Facility Layout

The development of facility layout for hospitals consists of the following steps:

- The first step involves collecting necessary information on facility layout objectives. This information comprises of work methods used, number of human resources required, instrument or machine utilization, cycle time (typically for micro layout e.g. operation theatre, laboratories), flexibility, etc.
- Data is gathered on the number of trips made, list of departments in the hospital and their areas, number of instruments and machines required, human ergonomic requirements, automatic and manual activities, etc.
- A capacity model is build up for determining the required number of instruments, machines, and departments presently and the required increase in the area based on future demand needs.
- A space and transaction analysis is performed for determining the size of the departments and relationship between the departments.
- Various layout options are analyzed using decision matrices.

- For micro layouts, storage requirements, flow of materials and human resources, and number of workstations required is been analyzed [41].

The flowchart for the layout design steps is presented in Figure 3.1

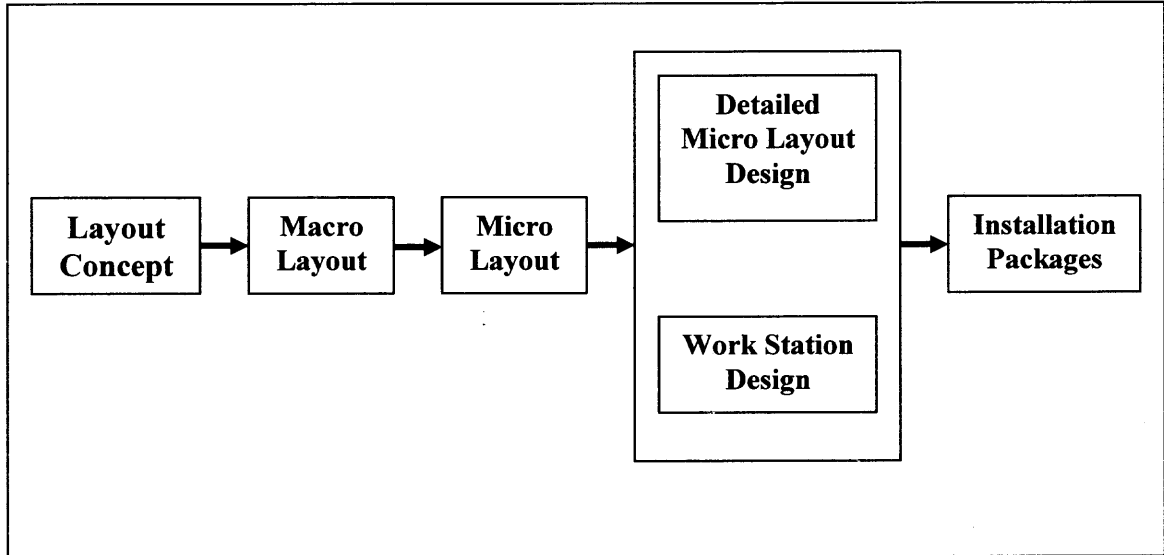

Figure 3.1 Flowchart for layout design.

3.3 Representation of the Hospital Facility Layout

The problem consists of generating an efficient facility layout for a hospital having 'n' departments. One elevator is used for transportation in the vertical direction. The elevator is accessible on the basis of availability, and the capacity of the elevator is neglected for simplicity. The elevator is initially positioned while setting the floor dimensions. The position of the elevator is denoted by (X_e, Y_e) and is fixed throughout the model.

Where,

X_e = X co-ordinate of elevator from the point (0, 0)

Y_e = Y co-ordinate of elevator from the point (0, 0).

The hospital facility layout design consists of determining the movement cost by assuming the placement of the departments on a rectangular floor area. The interior details of the arrangement, entry and exit point locations and movement details are neglected for simplicity. The travel entities are assumed to follow a rectilinear distance path between the two departments.

To start with, the departments are arranged alphabetically and placed onto floors on the basis of their areas. The sequence of the departments is partitioned into subsets. Each subset contains as many departments as can be fitted on a single floor [20, 31]. The interaction between departments is initially ignored.

The area of the i^{th} department is denoted by A_i and its location is obtained from the placement co-ordinates F_i , X_i and Y_i

Where,

F_i = Floor on which department is placed.

X_i = X co-ordinate of the department from the point (0, 0)

Y_i = Y co-ordinate of the department from the point (0, 0)

Area Analysis:

The total area of a department is the sum of required areas for patient rooms, bathrooms, storage space, nursing stations and other necessary spaces. This area is divided with number of patient beds required within a particular department.

The area per patient bed is an appropriate index of space adequacy in determining the total area requirement for a hospital. An overall average of 700sq.ft to 800sq.ft per hospital bed is the standard specification used [40]. Table 3.1 shows the area allocation for the departments of Saint Michael's Medical Center. Notations used to denote the

departments are given from the floor design perspective. The total area of all hospital departments of Table 3.1 is 181,000sq.ft or 774sq.ft for each of hospital's 150 beds.

Table 3.1 Hospital Departments and Area Allocation

i	Department Name	Notation	Area (sq.ft)
1	Anesthesia room	AR	1600
2	Birth center	BC	1800
3	Blood bank	Blood	3600
4	Blood testing	BT	1200
5	Cafeteria	Café	4000
6	Cashier's office	Pay	600
7	Cath lab	CL	1800
8	Cobalt machine lab	CoM/C	2200
9	Computed tomography scan	CT	2100
10	Conference room	CR	2700
11	Doctors room	DR	6000
12	Examination room	ER	2100
13	General ward	GW	12500
14	Hematology lab	HL	1650
15	Inpatient registration	InReg	800
16	Intensive care unit	ICU	6500
17	Linear accelerator lab	LINAC	1500
18	Mammography lab	M	2000
19	Medical records room	MRR	2800
20	Nurses room	NR	4000
21	Nutrition services	NS	2500
22	Obstetrics and gynecology ward	OGW	5000
23	Operation theatre	OT	4300
24	Orthovoltage lab	OvoIM/C	2500
25	Outpatient registration	OutReg	1000
26	Pharmacy	Phar	2400
27	Planning computer lab	PC	1200
28	Recovery room	RR	2400
29	Rehabilitation center	RehabC	4100
30	Social services	SS	1600
31	Special ward	SW	8750
32	Specialty clinic	SC	8000
33	Surgical equipments room	SeqR	2200
34	Ultrasonography lab	U	1800
35	Waiting room	WR	3900
36	Walk-in-clinic	WIC	2200
37	X-ray lab	X	1600
38	X-ray simulator lab	S	1200

Floor Dimensions:

Figure 3.2 represents a typical floor of the hospital building. The position of the elevator is indicated. A uniform passage passes through the center of the building and the departments are located along the sides. The hospital building is assumed to be rectangular in shape with length 'L' and width 'W'. All floors have the same dimensions.

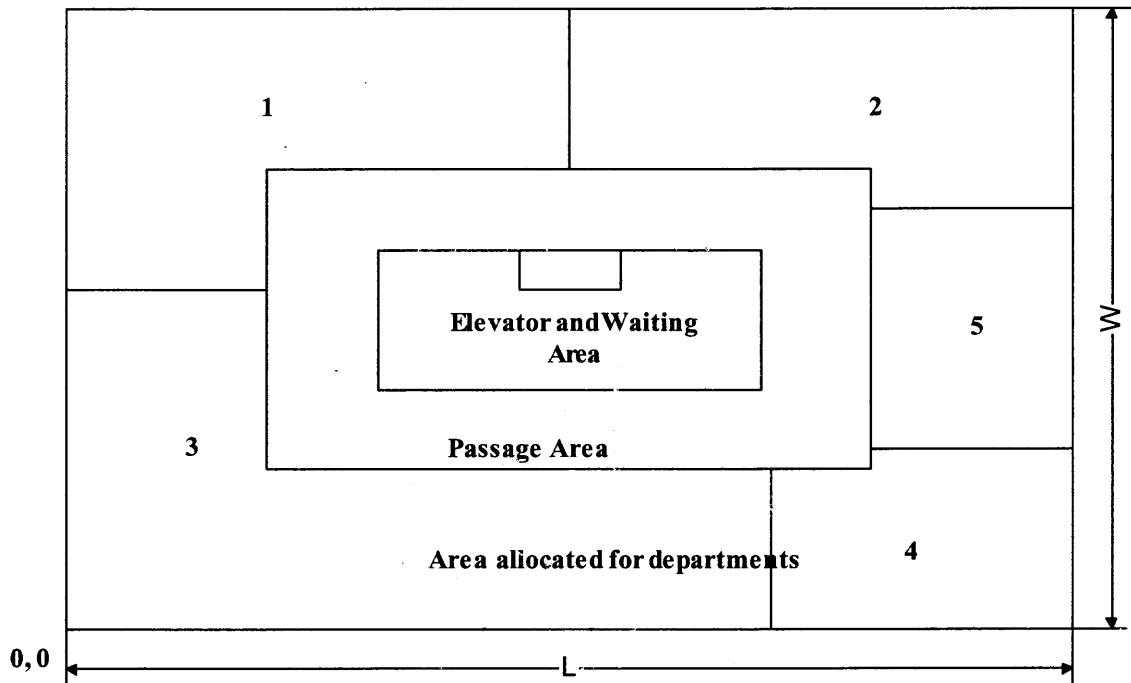

Figure 3.2 Floor dimensions for the hospital building.

3.4 Attributes for Deriving the Movement Cost

The movement cost is directly proportional to the distance, travel frequency, trip difficulty rating, and baseline travel cost and thus, varying any of the attributes changes the movement cost. The optimal solution is obtained by running simulations with the aim of altering one or some of these attributes.

3.4.1 Distance Attribute

Distance is the most important attribute in designing any facility layout problem. All the facility layouts are designed with aim of reducing the distance between two departments, as it is dependent on the layout plan used for the facility [31].

The distance matrix is calculated by pairing each location ‘i’ with another location ‘j’. Multi-floor facility layouts comprise of the horizontal and vertical component for the distance attribute. The vertical component is given five times the weights compared to the horizontal component to account for average transport and waiting times for the movements in the building.

Distance between two departments located on the same floor (horizontal distance) is given by

$$D_{ij} = |X_i - X_j| + |Y_i - Y_j|$$

Distance between two departments located on different floors (horizontal + vertical distances) is given by

$$D_{ij} = |X_i - X_e| + |Y_i - Y_e| + \delta |F_i - F_j| + |X_j - X_e| + |Y_j - Y_e|$$

Where,

(X_i, Y_i) = X and Y co-ordinates of the first department from the point (0, 0).

(X_j, Y_j) = X and Y co-ordinates of the second department from the point (0, 0).

$(X_e, Y_e) = X$ and Y co-ordinates of elevator from the point $(0, 0)$.

F_i = Floor on which first department is located.

F_j = Floor on which the second department is located.

δ = Factor for transport in vertical direction and waiting times = 5

The distance matrix is calculated with the above formulae, which gives the distance between each pair of departments. Table 3.2 shows the distance matrix for five departments. 'X' indicates no movements are facilitated.

Table 3.2 Distance Matrix

i \ j	1	2	3	4	5
1	X	D_{12}	D_{13}	D_{14}	D_{15}
2	D_{21}	X	D_{23}	D_{24}	D_{25}
3	D_{31}	D_{32}	X	D_{34}	D_{35}
4	D_{41}	D_{42}	D_{43}	X	D_{45}
5	D_{51}	D_{52}	D_{53}	D_{54}	X

3.4.2 Travel Frequency Attribute

The travel frequency attribute represents the number of trips made from one department to another. In facility layout problems, travel frequency is usually kept constant throughout the model. The minimization of movement cost by reducing the number of trips made between departments is sometimes possible if some special portable devices are used to reduce the patient movements [7, 31, 32, 33].

The travel frequency is denoted by T_{ijk} , which represents the number of trips made from department 'i' to department 'j' by an entity 'k'. The entities are typically

classified as patients, doctors, medical and non-medical staff. Table 3.3 shows the travel frequency matrix for three departments. 'X' indicates that no movements take place.

Table 3.3 Travel Frequency Matrix

$i \backslash j$	1	2	3
1	X	T_{121}	T_{131}
		T_{122}	T_{132}
		T_{123}	T_{133}
		T_{124}	T_{134}
2	T_{211}	X	T_{231}
	T_{212}		T_{232}
	T_{213}		T_{233}
	T_{214}		T_{234}
3	T_{311}	T_{321}	X
	T_{312}	T_{322}	
	T_{313}	T_{323}	
	T_{314}	T_{324}	

3.4.3 Trip Difficulty Rating

Hospitals involve movements of patients to a large extent. Patients in a hospital encounter difficulty in movement and may sometimes even require some resource to move depending on their physical condition. Movements of other entities like doctors, medical staff and non-medical staff also take place to a considerable extent.

The level of difficulty in motion affects the movement cost i.e. movement cost is less for unassisted movement compared to movement requiring help. Movement cost is thus directly proportional to trip difficulty. The trip difficulty ratings are fixed attributes. After they have been assigned they are kept constant throughout the model.

Movement difficulty is modeled by developing a trip difficulty rating scale [42]. The devised rating scale is different for different entities. For example, the rating scale used for modeling movement difficulty for patients cannot be used for modeling

movement difficulty for medical staff etc. The trip difficulty rating scale is shown in Table 3.4.

Table 3.4 Trip Difficulty Rating Scale.

Entities	Rating	Movement Description
Patients	1	Completely independent. Movement done without slowness and difficulty.
	1.25	Independent movement, but conscious of difficulty.
	1.5	Somewhat dependent, but sometimes requires another person for help.
	2	Mostly dependent, most often requires someone for help.
	2.5	Totally dependent, helpless.
Doctors	1	Completely independent. Movement done without slowness and difficulty.
Medical staff	1	Movement done freely.
	1.5	Movement done with a patient or some equipment.
Non-Medical Staff	1	Movement done freely.
	1.5	Movement done with a patient or some equipment.
	0	No movements.

The trip difficulty is denoted by ξ_{ijk} , which represents difficulty in movement from department 'i' to department 'j' by an entity 'k'. Table 3.5 shows the trip difficulty matrix for movements among three departments. 'X' indicates that no movements take place.

Table 3.5 Trip Difficulty Matrix

i \ j	1	2	3
1	X	ξ_{121}	ξ_{131}
		ξ_{122}	ξ_{132}
		ξ_{123}	ξ_{133}
		ξ_{124}	ξ_{134}
2	ξ_{211}	X	ξ_{231}
	ξ_{212}		ξ_{232}
	ξ_{213}		ξ_{233}
	ξ_{214}		ξ_{234}
3	ξ_{311}	ξ_{321}	X
	ξ_{312}	ξ_{322}	
	ξ_{313}	ξ_{323}	
	ξ_{314}	ξ_{324}	

3.4.4 Baseline Travel Cost

The variation in movement cost also depends on the human resources involved. For example, the cost of moving a doctor by a unit is not equal to the cost of moving a patient by a unit.

To account for this, a factor baseline travel cost is used in the model. Baseline travel cost is a cost factor, which assigns weight to the trip based on the moving human resource. It is assumed that the cost of moving a doctor by a unit is greater than the cost of moving medical staff by a unit, which is greater than the cost of moving a patient by a unit, which is greater than the cost of moving non-medical staff by a unit. Baseline travel

cost is a function of the movement cost. It is a fixed attribute, as the value assigned to each type of human resource remains unaltered throughout the model.

Baseline travel cost is denoted by α_k , which represents the cost factor assigned to entity 'k'. Table 3.6 shows the baseline travel cost factors assigned to the moving entities in a hospital in which $\alpha_2 > \alpha_3 > \alpha_1 > \alpha_4$.

Table 3.6 Baseline Travel Cost Factor

Variable	Description	Cost Factor
A	Cost of moving a patient	α_1
B	Cost of moving a doctor	α_2
C	Cost of moving a medical staff	α_3
D	Cost of moving a non-medical staff	α_4

3.5 Generation of the Cost Function

Given a set of departments and their area over a 2D space, a hospital facility layout problem determines the optimum placement of the department within the available space so that the value of the objective function is minimized. The cost function is developed considering numerous attributes that relate to the placement of departments and the movement of entities.

The movement cost is directly proportional to

- Distance between two departments, which depends upon the placement coordinates (D_{ij}).
- Travel frequency of entities between departments (T_{ijk}).

- Trip difficulty rating specifying the degree of entity movement difficulty between departments (ξ_{ijk}).
- Baseline travel cost factor assigned to a travel entity (α_k).

Mathematically, the objective function can be expressed as follows:

$$\sum_{i=1}^N \sum_{j=1}^N \sum_{k=1}^M T_{ijk} \cdot D_{ij} \cdot (\xi_{ijk} * \alpha_k)$$

Where,

N represents total number of departments.

M represents total number of travel entities.

The baseline travel cost factors for entities are multiplied with the difficulty rating values in the trip difficulty-rating matrix to form a new matrix (Baseline travel cost x Trip difficulty rating). Table 3.7 shows (baseline travel cost x trip difficulty rating) matrix for movements among three departments.

Table 3.7 Baseline Travel Cost x Trip Difficulty Rating Matrix

i \ j	1	2	3
1	X	$\xi_{121} * \alpha_1$	$\xi_{131} * \alpha_1$
		$\xi_{122} * \alpha_2$	$\xi_{132} * \alpha_2$
		$\xi_{123} * \alpha_3$	$\xi_{133} * \alpha_3$
		$\xi_{124} * \alpha_4$	$\xi_{134} * \alpha_4$
2	$\xi_{211} * \alpha_1$	X	$\xi_{231} * \alpha_1$
	$\xi_{212} * \alpha_2$		$\xi_{232} * \alpha_2$
	$\xi_{213} * \alpha_3$		$\xi_{233} * \alpha_3$
	$\xi_{214} * \alpha_4$		$\xi_{234} * \alpha_4$
3	$\xi_{311} * \alpha_1$	$\xi_{321} * \alpha_1$	X
	$\xi_{312} * \alpha_2$	$\xi_{322} * \alpha_2$	
	$\xi_{313} * \alpha_3$	$\xi_{323} * \alpha_3$	
	$\xi_{314} * \alpha_4$	$\xi_{324} * \alpha_4$	

The new matrix generated is multiplied with the distance matrix and the travel frequency matrix to generate the movement cost matrix. The summation of the values of the objective function matrix gives the total movement cost, and the objective of modeling a hospital facility layout problem is to minimize this movement cost. Table 3.8 shows the movement cost matrix.

Table 3.8 Movement Cost Matrix

i \ j	1	2	3
1	X	$T_{121} * D_{12}(\xi_{121} * \alpha_1)$	$T_{131} * D_{13}(\xi_{131} * \alpha_1)$
		$T_{122} * D_{12}(\xi_{122} * \alpha_2)$	$T_{132} * D_{13}(\xi_{132} * \alpha_2)$
		$T_{123} * D_{12}(\xi_{123} * \alpha_3)$	$T_{133} * D_{13}(\xi_{133} * \alpha_3)$
		$T_{124} * D_{12}(\xi_{124} * \alpha_4)$	$T_{134} * D_{13}(\xi_{134} * \alpha_4)$
2	$T_{211} * D_{21}(\xi_{211} * \alpha_1)$	X	$T_{231} * D_{23}(\xi_{231} * \alpha_1)$
	$T_{212} * D_{21}(\xi_{212} * \alpha_2)$		$T_{232} * D_{23}(\xi_{232} * \alpha_2)$
	$T_{213} * D_{21}(\xi_{213} * \alpha_3)$		$T_{233} * D_{23}(\xi_{233} * \alpha_3)$
	$T_{214} * D_{21}(\xi_{214} * \alpha_4)$		$T_{234} * D_{23}(\xi_{234} * \alpha_4)$
3	$T_{311} * D_{31}(\xi_{311} * \alpha_1)$	$T_{321} * D_{32}(\xi_{321} * \alpha_1)$	X
	$T_{312} * D_{31}(\xi_{312} * \alpha_2)$	$T_{322} * D_{32}(\xi_{322} * \alpha_2)$	
	$T_{313} * D_{31}(\xi_{313} * \alpha_3)$	$T_{323} * D_{32}(\xi_{323} * \alpha_3)$	
	$T_{314} * D_{31}(\xi_{314} * \alpha_4)$	$T_{324} * D_{32}(\xi_{324} * \alpha_4)$	

3.6 Illustrative Example

The applicability of the proposed formulation is illustrated with an example, which is been used throughout the thesis. A facility layout is designed for a 150-bed hospital having 38 departments. Each floor has a total area of 25,000sq.ft of which 2100sq.ft is passage area and 1500sq.ft is elevator and waiting areas. The available area for placement of departments is 21400sq.ft per floor. The dimensions are the same for all floors of the building.

To start with developing a layout, a department sequence is generated by arranging the departments in alphabetical order. These departments are placed manually onto the floors based on their areas starting with the first department and following a counter-clockwise rotation. Each floor consists of as many departments as can be accommodated. To place all departments, seven floors are required. The floor layout is generated using a scale of 1:10. The placement co-ordinates are calculated from point (0, 0) of each floor and are assumed to be located at the center of gravity of the geometrical shape. The distance matrix is developed from the placement co-ordinates considering rectilinear distance measures as explained in Section 3.4.1. The travel frequency matrix is created from the travel frequencies between two respective departments per week. The frequency values are obtained from the survey at the Saint Michael's Medical Center, Newark, NJ. The developed matrix looks as it is shown in Table 3.3 in Section 3.4.2. For example, consider department 1 to be the General Ward and department 2 the Operation theatre in Table 3.3 and if $T_{121} = 15$, $T_{122} = 5$, $T_{123} = 25$, $T_{124} = 10$, then 15 trips are made from general ward to operation theatre by patients, 5 trips by doctors, 25 trips by medical staff, and 10 trips by other non-medical staff weekly. The (Trip Difficulty Rating x

Baseline Travel Cost) matrix is created. The trip difficulty ratings are given to each pair of departments for each type of travel entities based on the generated rating scale as explained in Section 3.4.3. The baseline travel costs are assumed to be ($\alpha_1 = 10$, $\alpha_2 = 20$, $\alpha_3 = 15$, $\alpha_4 = 5$) so that $\alpha_2 > \alpha_3 > \alpha_1 > \alpha_4$. Lastly, the movement cost matrix is developed from the above matrices, and the objective function value is computed. The total movement cost associated with all entities shown in Table 3.9.

Table 3.9 Experimental Results from Sample Layout

Entities	Movement Cost
Patients	\$ 1,533,804.30
Doctors	\$ 1,503,259.80
Medical Staff	\$ 2,343,224.81
Non-Medical Staff	\$ 562,571.29
Total	\$ 5,942,860.20

Experimental Results:

The experimental results show that the cost of moving doctors and medical staff is comparatively higher than that for non-medical staff, since doctors and medical staff serve as accompanying resources to patients to serve their needs and facilitate their movements. The experimental results also show that the total cost of movement of medical staff is greater than that of doctors, since nurses, laboratory staff, etc. have to make more trips than doctors to serve many urgent patient needs and it is often done with some equipment. Doctor movements are made for surgery, examination, clinical checks, in case of emergency, etc and usually they are not accompanied by equipment.

Reducing the cost of patient movements would result in decreasing the cost of moving secondary resources as well, thereby minimizing the total movement cost. This is made possible by arranging the hospital departments in an optimal way.

The floor layouts for the sample layout are represented in Figures 3.3 to 3.9 showing the arrangement of departments on all seven floors. The floor layouts are drawn to a scale of 1:10.

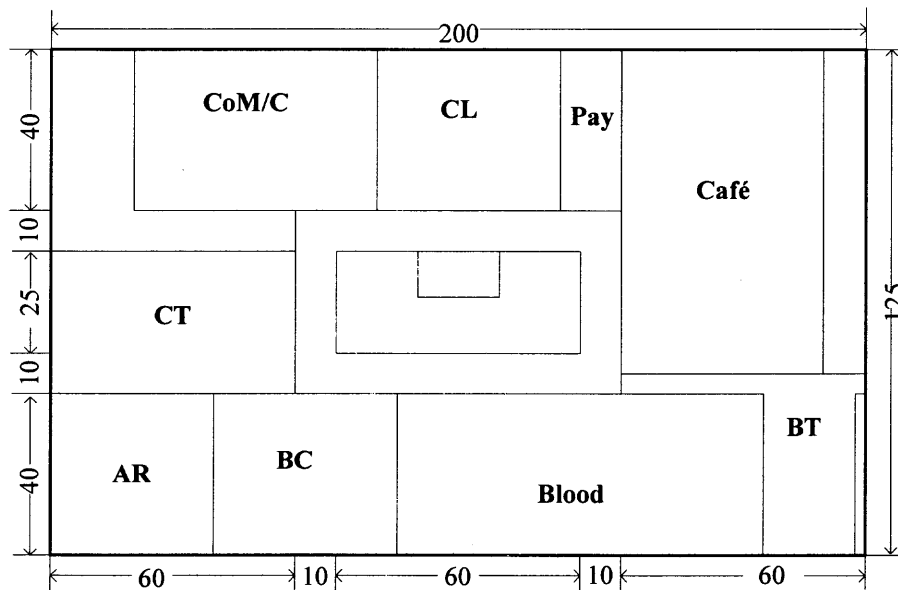

Figure 3.3 Sample floor1 layout.

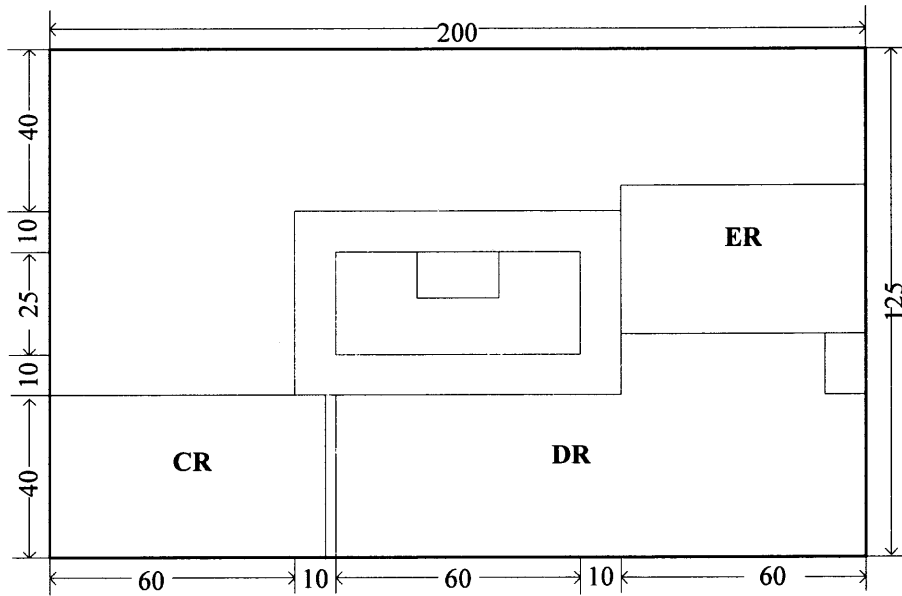

Figure 3.4 Sample floor2 layout.

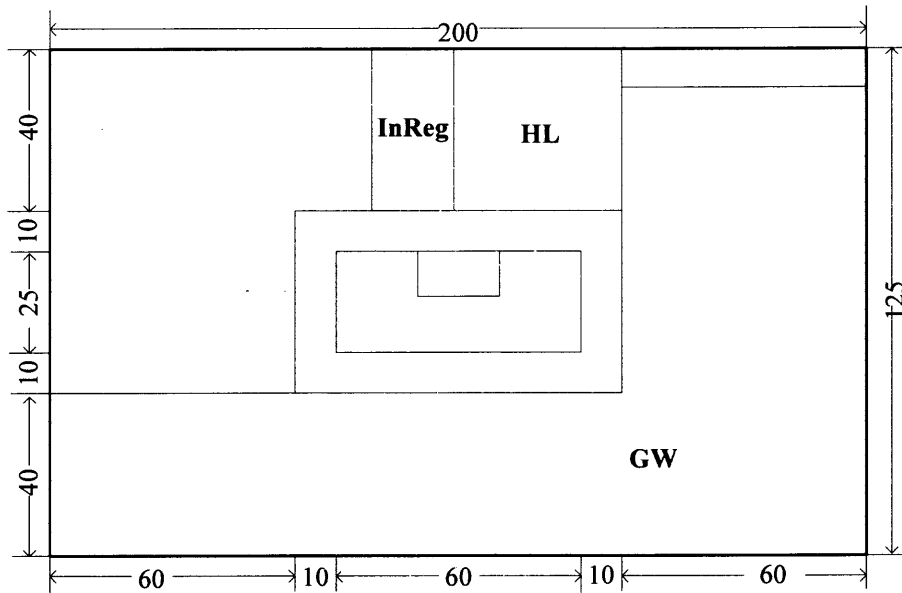

Figure 3.5 Sample floor3 layout.

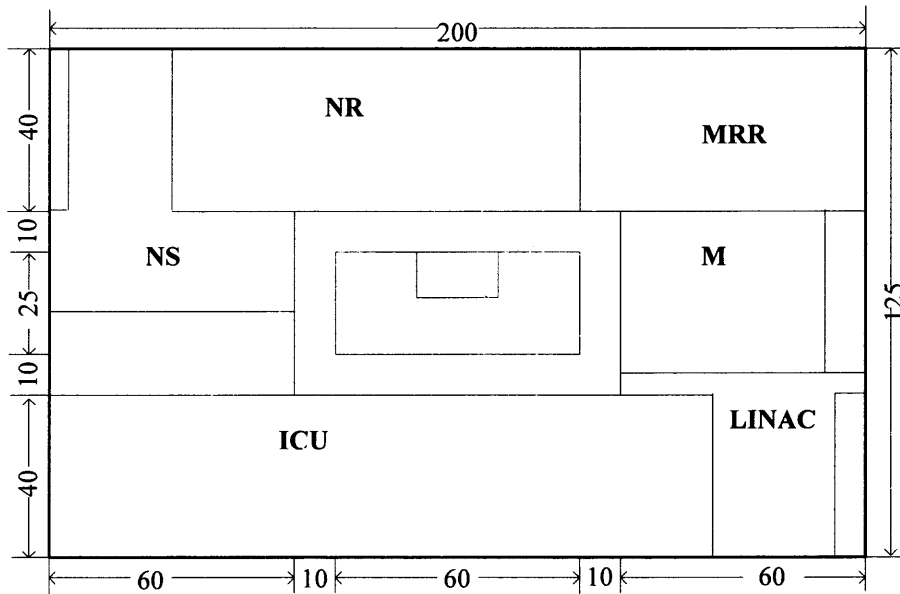

Figure 3.6 Sample floor4 layout.

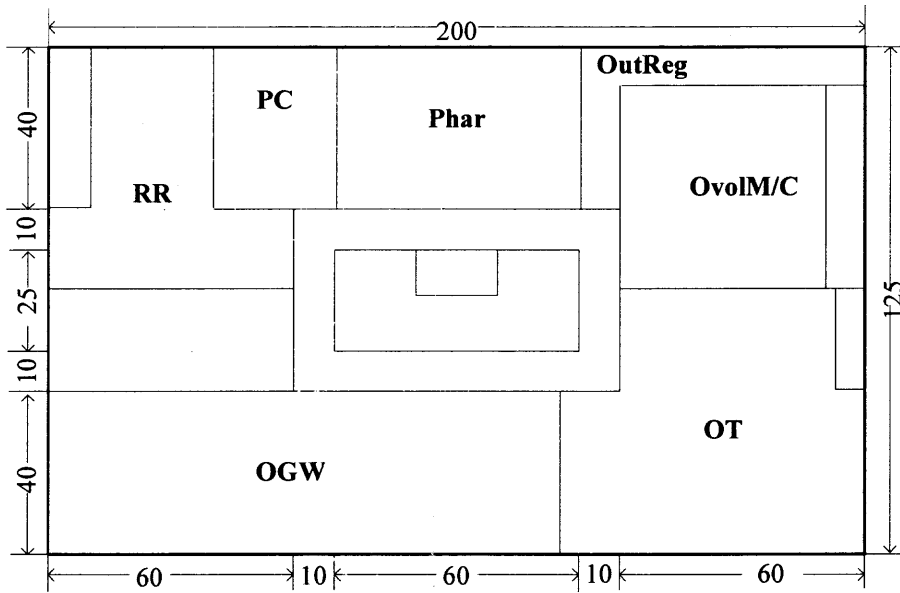

Figure 3.7 Sample floor5 layout.

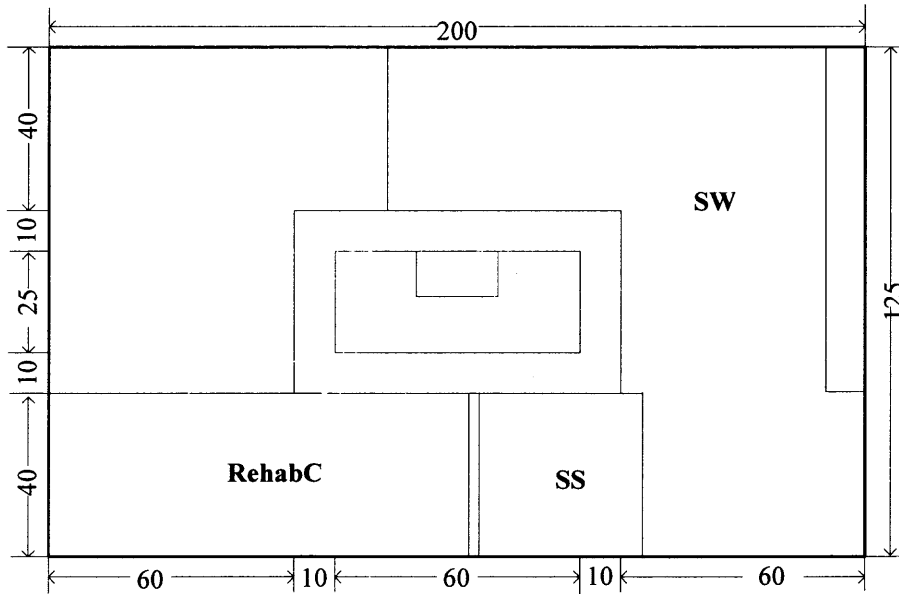

Figure 3.8 Sample floor6 layout.

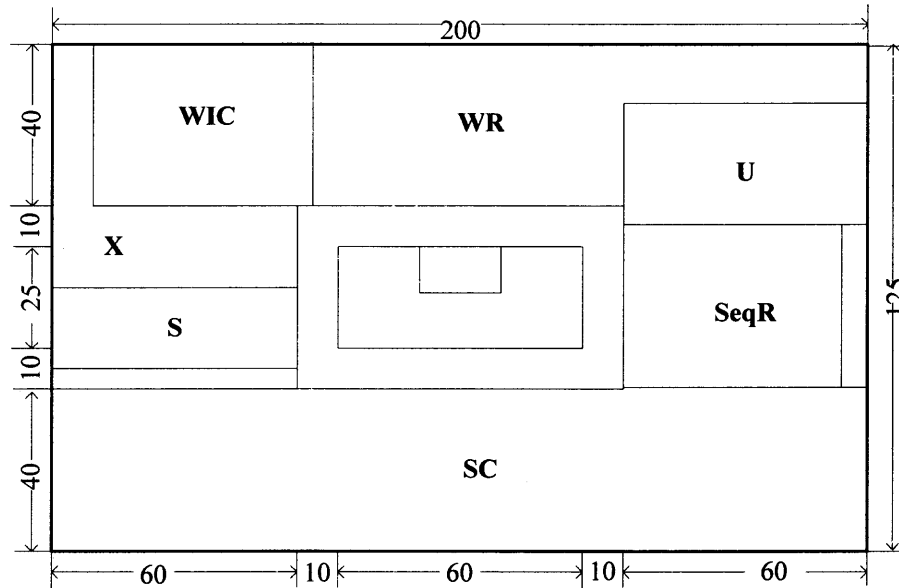

Figure 3.9 Sample floor7 layout.

CHAPTER 4

STRATEGIES FOR OPTIMAL LAYOUT

4.1 Facility Layout Design with Area Considerations and Elevator Closeness Index

In multi-floor facility layout problems, movements of entities occur in both the horizontal and vertical direction. The flow of traffic in hospitals is significantly large compared to a manufacturing plant, and includes considerable flow in the vertical direction. Arranging the departments in a hospital by monitoring the flow of traffic to different floors would result in minimizing the movement cost [7, 31, 32].

A parameter Elevator Closeness Index (E.C.I) is introduced to the facility layout design. The Elevator Closeness Index is derived on the basis of the number of trips made from the departments to different floors as follows:

$$\text{ElevatorClosenessIndex}(E.C.I)_i = \frac{E_n}{E_t}$$

Where,

E_n = Total number of trips made by entities from a particular department to different floors.

E_t = Total number of trips including trips made to departments on the same floor

Typically, the E.C.I is the index value assigned to departments, to specify their derived closeness to the elevator relative to another department located on the same floor. For departments located on the same floor, the department having higher E.C.I value is placed closer to the elevator than the department with a lower value. The value of E.C.I changes with the layout as it is based on the measure of interaction of a particular department with departments located on different floors.

Experimentation and Results

The facility layout model is designed by introducing the Elevator Closeness Index (E.C.I). The sample layout is modified to incorporate this parameter. The department areas and the floor dimensions are unaltered. The hospital is considered to be a 7-storey building, and the department allocation to floors is the same as that of the sample layout.

Simulations are run to generate an efficient layout, which would minimize the movement cost. The best solution is chosen from layouts producing a movement cost value which is less than that for the sample layout. This layout is considered to be the optimal layout for the corresponding strategy.

Table 4.1 Simulation Results for Layout Strategy1

Entities	Travel Cost
Patients	\$ 1,505,904.59
Doctors	\$ 1,446,936.35
Medical Staff	\$ 2,270,429.75
Non-Medical Staff	\$ 553,076.93
Total	\$ 5,776,347.62

Table 4.1 shows simulation results from this layout strategy for the best possible layout generated. From the experimental results, it is observed that as the total cost of moving a patient goes down; the cost of moving secondary resources also decreases, thereby decreasing the total movement cost. This is made possible by bringing departments having high traffic closer to the elevator.

The floor layouts for simulation strategy1 are represented in Figures 4.1 to 4.7, which give the new locations of departments obtained from altering the sample layout. The position of the departments is changed with respect to their elevator closeness index (E.C.I).

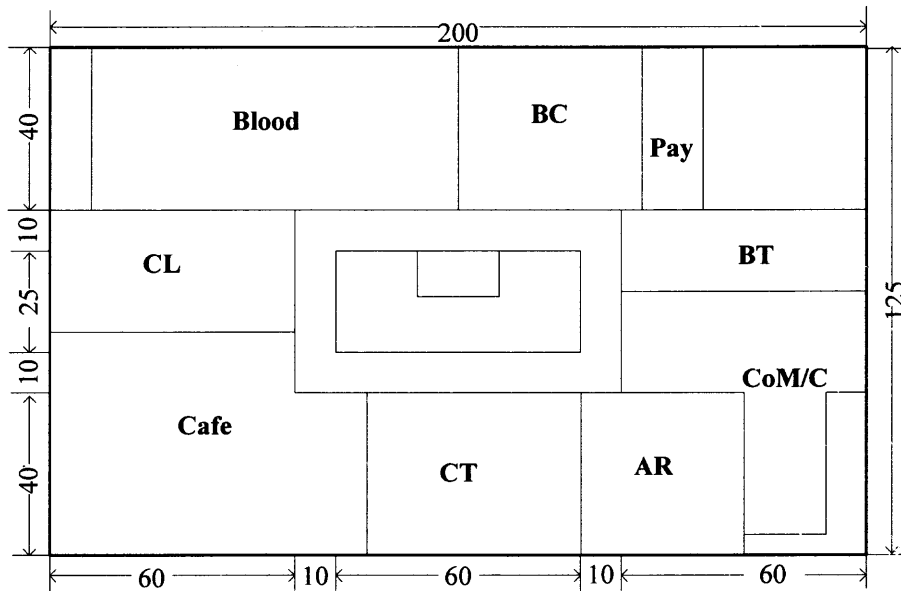

Figure 4.1 Floor1 layout for simulation strategy1.

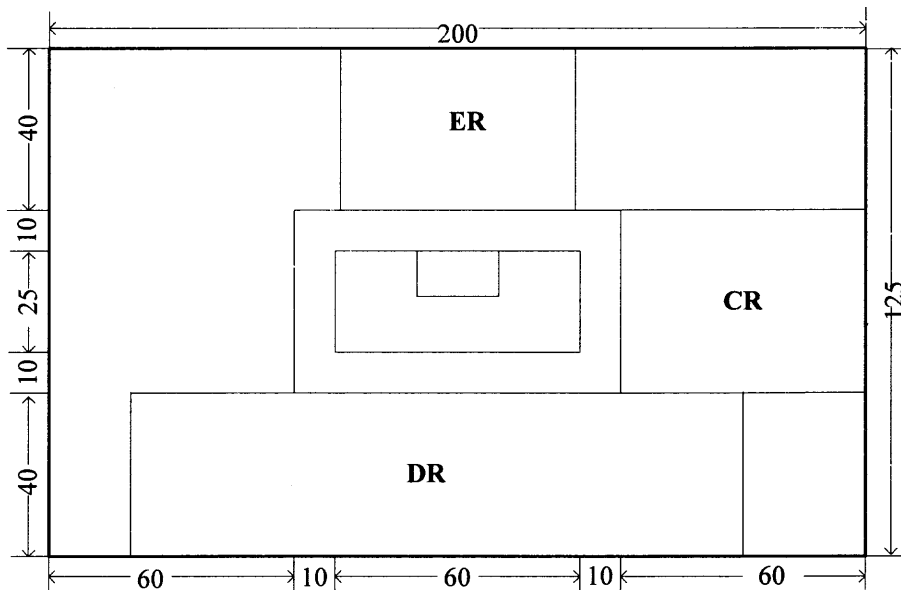

Figure 4.2 Floor2 layout for simulation strategy1.

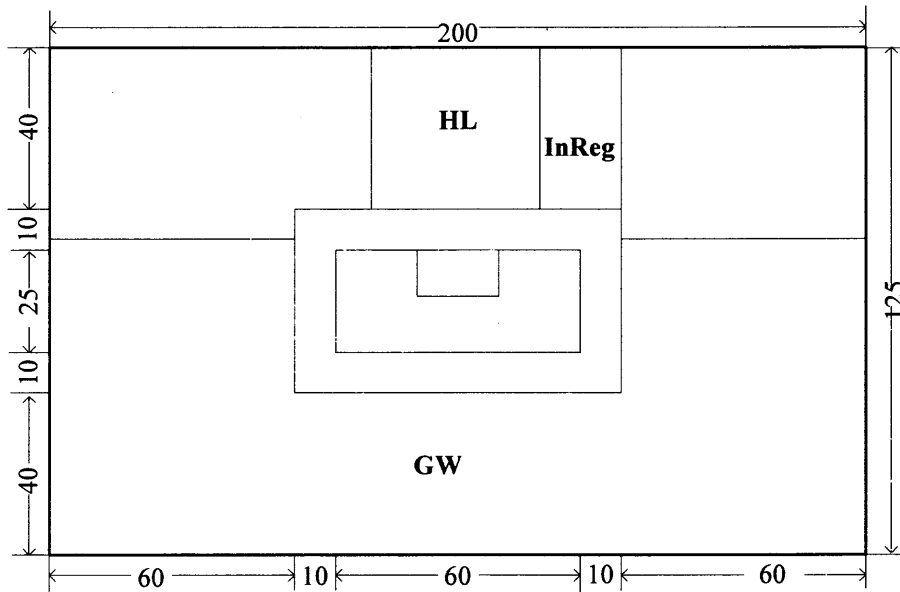

Figure 4.3 Floor3 layout for simulation strategy1.

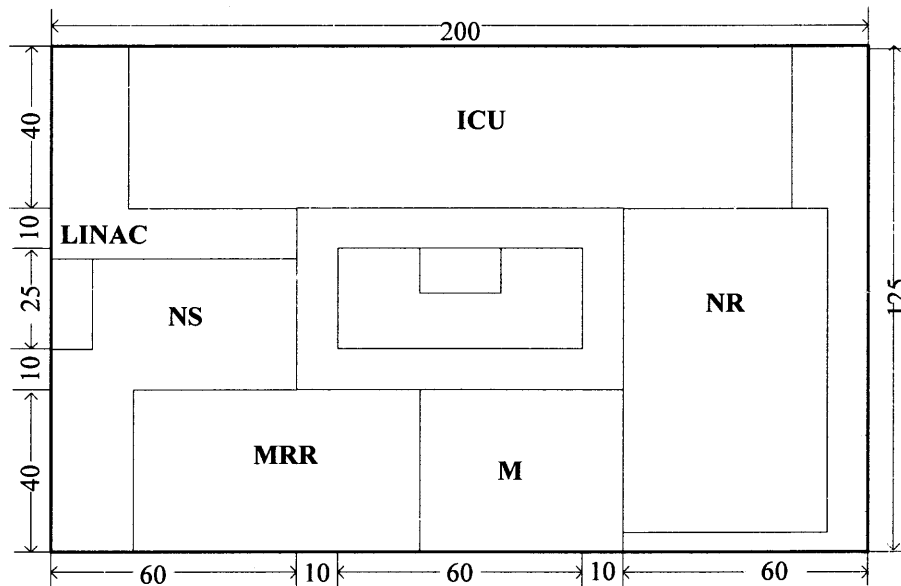

Figure 4.4 Floor4 layout for simulation strategy1.

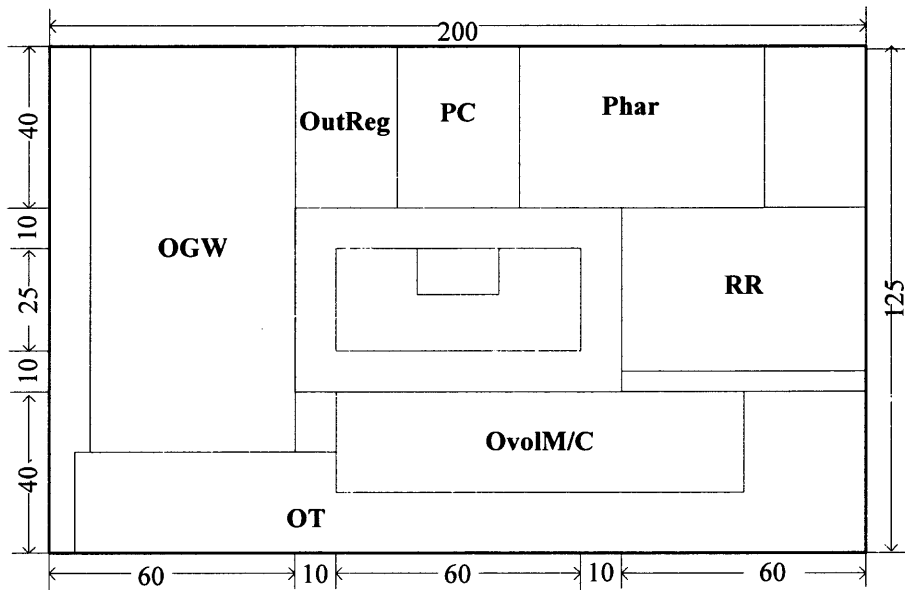

Figure 4.5 Floor5 layout for simulation strategy1.

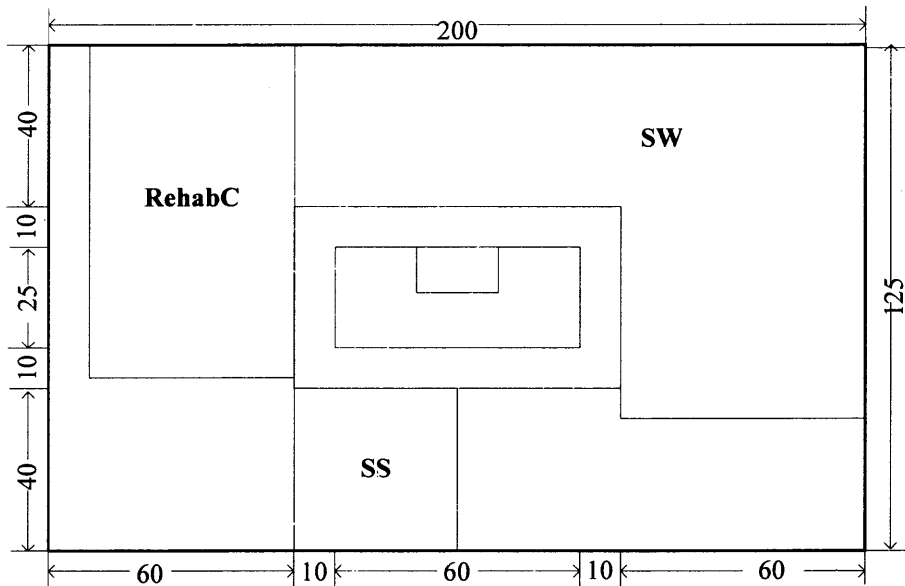

Figure 4.6 Floor6 layout for simulation strategy1.

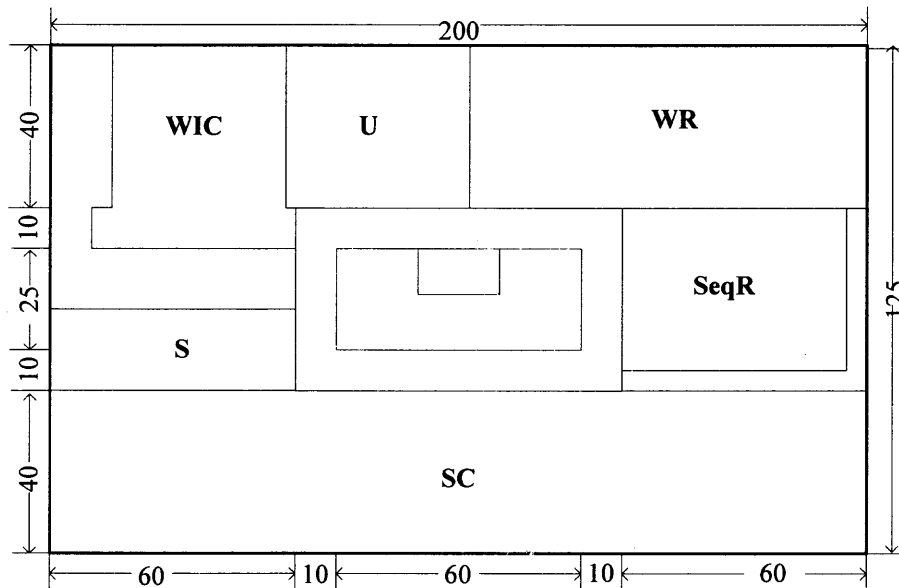

Figure 4.7 Floor7 layout for simulation strategy1.

4.2 Facility Layout Design Using Area considerations, E.C.I and Relationship Matrix

The primary aspect of facility layout design is the interaction between the departments in a building. Considering the interaction between departments results in efficient placement, by reducing the distance between them and minimizing the movement cost [31, 32]. In addition, the placement of departments based on the relationships results in faster response to patient needs.

The placement of the departments into an optimal number of floors is also desirable, since reducing the placement area decreases the distance to be traveled on additional floors. The calculation of the number of floors is obtained using the total area of departments, elevator, passage areas and theoretical area of the floor as input parameters. The number of floors for the hospital building is determined as follows (Refer Appendix A for derivation):

$$f = \frac{A_i}{[A_{th} - (A_e + A_p)]}$$

Where,

A_i = Total area occupied by the departments.

A_{th} = Theoretical area of the floor.

A_e = Elevator and waiting areas.

A_p = Passage area.

Experimentation and Results

A facility layout is designed with departments placed in a 6-storeyed building, as dictated by the above equation. Their closeness to the elevator and relationship among them is determined from the number of trips made.

The departments are arranged onto floors based on the Elevator Closeness Index (E.C.I) and the Relationship matrix. The departments having a higher E.C.I are placed closer to the elevator. The relationship matrix is developed based on the number of trips taking place between departments. Table 4.2 shows the relationship value chart, which is developed by dividing the range of observed trips between departments into five equal parts. The desired closeness between a given department pair is a function of and proportional to the travel frequency between the departments.

Table 4.2 Relationship Value Chart

Value	Closeness	Number of trips per week
A	Absolutely necessary	200 – 249
E	Especially important	150 – 199
I	Important	100 – 149
O	Ordinary closeness	50 – 99
U	Unimportant	0 – 49

The Relationship matrix is developed from the relationship value chart. The facility layout design constraints the placement of the departments having relationship values of 'A' or 'E' onto the same or the next consecutive floor, whereas those having relationship values of 'I', 'O' and 'U' can be placed further away. Table 4.3 represents the relationship matrix for five departments.

Table 4.3 Relationship matrix

i				
1				
	A			
2		I		
	U		U	
3		E		O
	U		U	
4		U		
	O			
5				

Simulations are run by incorporating these additional constraints into the model, and the layout which minimizes the travel cost is selected. The best solution is chosen from the layouts having a movement cost value lower than that obtained in Section 4.1.

Table 4.4 Simulation Results for Layout Strategy2

Entities	Movement Cost
Patients	\$ 1,228,721.03
Doctors	\$ 1,218,799.48
Medical Staff	\$ 2,033,001.36
Non-Medical Staff	\$ 463,312.79
Total	\$ 4,943,834.66

Table 4.4 shows simulation results from this layout strategy for the best possible layout. Strategy2 reduces significantly the original total movement cost of Strategy1. The results validate the idea that decreasing the movement cost of patients causes a decrease in the movements cost of doctors, medical and non-medical staff. This strategy requires 6 instead of 7 floors, but the capital cost is neglected.

The floor layouts for 6 floors are shown in Figures 4.8 to 4.13, showing the department arrangement for the best generated strategy.

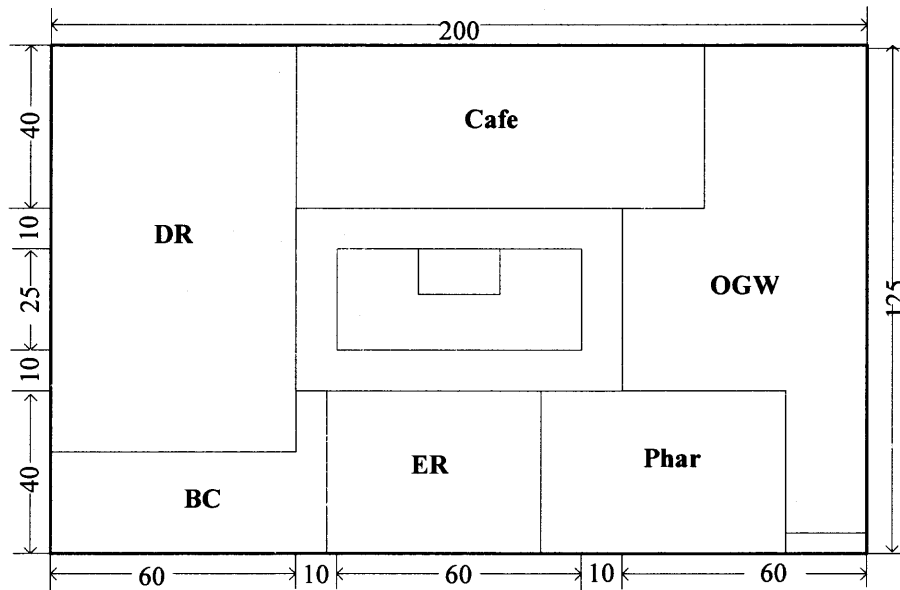

Figure 4.8 Floor1 layout for simulation strategy2.

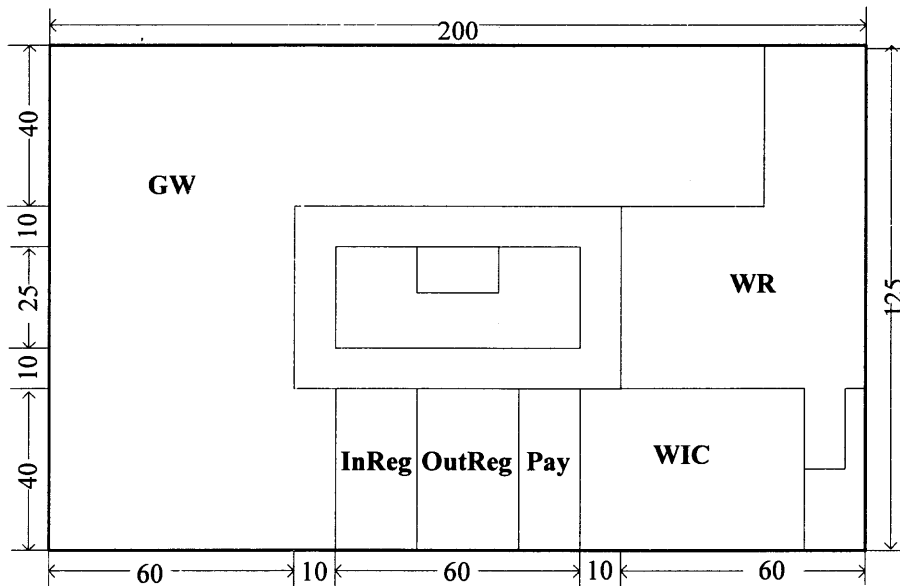

Figure 4.9 Floor2 layout for simulation strategy2.

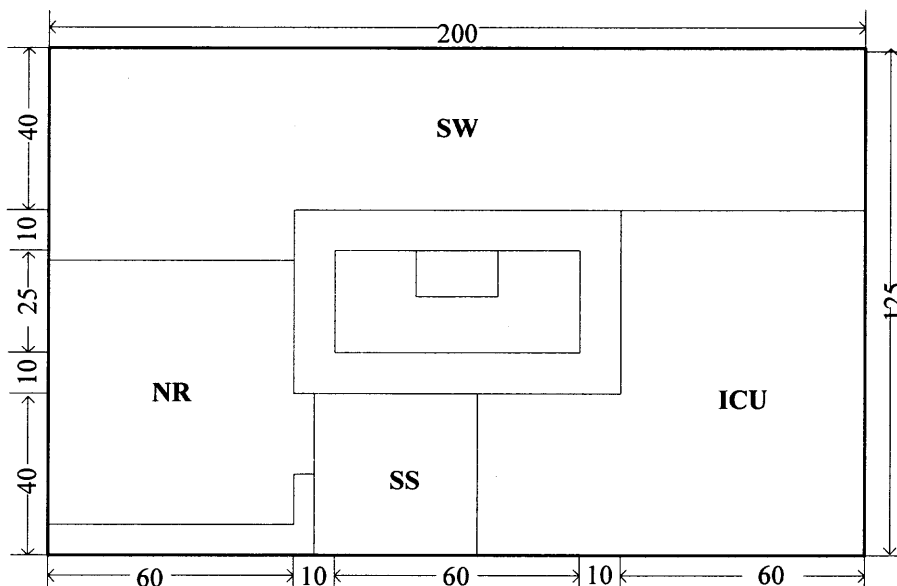

Figure 4.10 Floor3 layout for simulation strategy2.

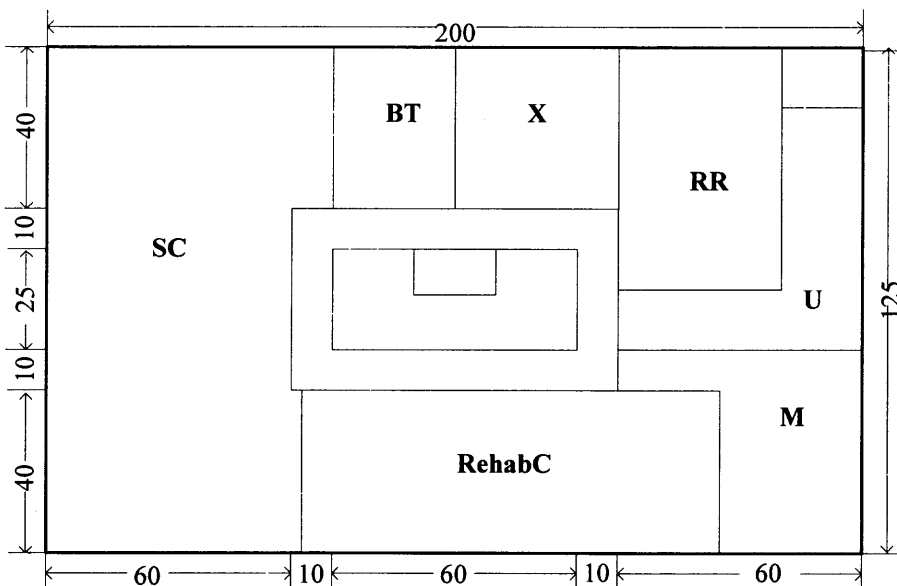

Figure 4.11 Floor4 layout for simulation strategy2.

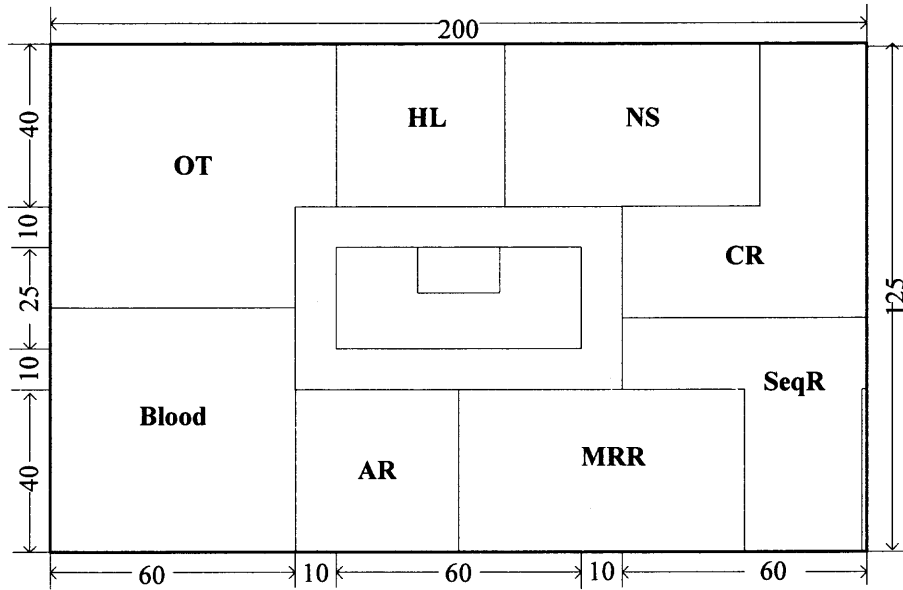

Figure 4.12 Floor5 layout for simulation strategy2.

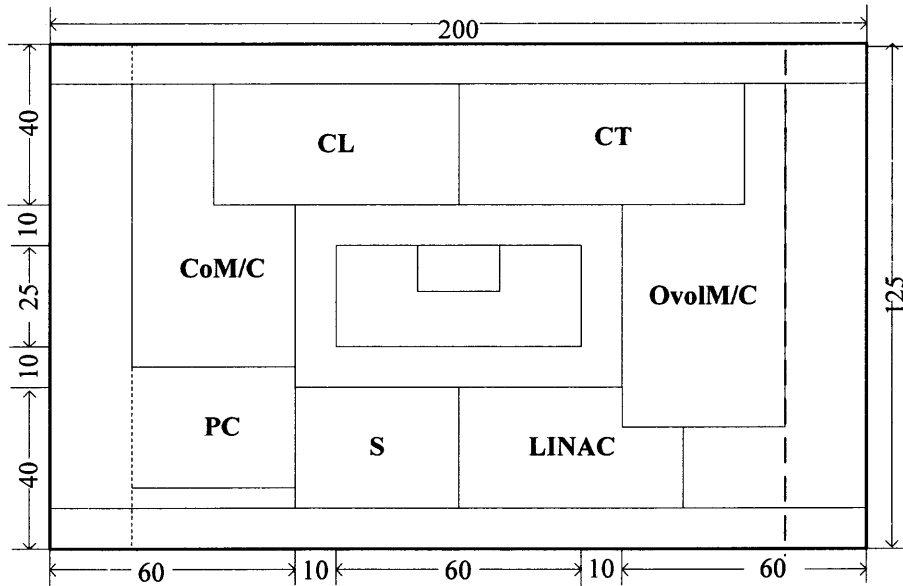

Figure 4.13 Floor6 layout for simulation strategy2.

4.3 Facility Layout Design by Splitting Departments onto Different Floors

The combination of providing high quality service to patients along with efficiently analyzing the flow of traffic is desirable in hospital facility layout design [31, 39]. In hospitals, flow of traffic into departments where patients reside is maximum. Thus the cost could be reduced, if some of these departments are split into different floors.

For department splitting to be beneficial, the departments to be split on different floors should have a large area and high traffic between them, and should be currently located in different floors. Doctors, medical and non-medical staff have to travel comparatively shorter distances to provide service to patients, as only a fraction of them needs to travel longer distances than before. For example, if the general ward and nurses room are located into two different floors and are split so that each split piece of the general ward is on the same floor as that of the nurses room, then the travel entities associated with the movement between them do not have to travel a vertical distance. The flow of traffic is diverted in the same ratio as the area of the split departments.

Experimentation and Results

A facility layout model is designed by splitting five departments (GW, SW, ICU, OGW, ICU) having large area and heavy traffic. Each department is split into two equal pieces for simplicity and the traffic is diverted in the same proportion. The internal flow among the split pieces is assumed to be small for simplicity. The facility layout design does not focus on the micro layout for each department. The model is constrained for closeness to the elevator and the relationships are the same as in previous strategies. The split pieces are considered as individual departments for modeling purposes and thus the elevator closeness index (E.C.I) for the split pieces is different.

Simulations are run and it is observed that there is a reduction in movement cost as compared to that obtained from the strategy of Section 4.2. Simulations also show that if more departments are split, the movement cost is decreased more. However the departments to be split must satisfy the criteria of having large area and high traffic. Table 4.5 shows the simulation results obtained from this layout strategy.

Table 4.5 Simulation Results for Layout Strategy3

Entities	Movement Cost
Patients	\$ 1,226,505.53
Doctors	\$ 1,212,428.59
Medical Staff	\$ 1,977,717.35
Non-Medical Staff	\$ 442,098.33
Total	\$ 4,858,749.80

Figures 4.14 to 4.19 represent the layout of the 6 floors for this layout strategy. The placement of the split departments is made on the first four floors keeping the layout of the 5th and 6th floor the same as in strategy2.

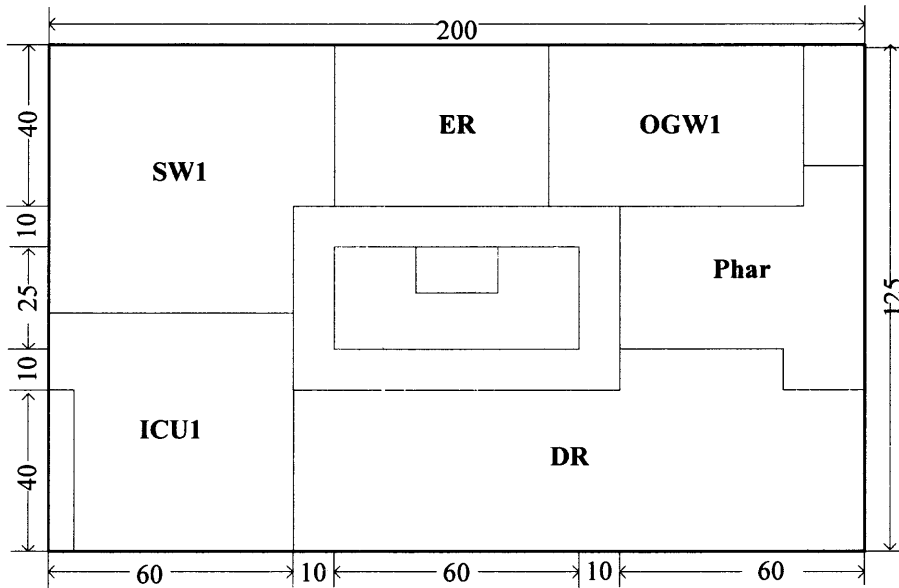

Figure 4.14 Floor1 layout for simulation strategy3.

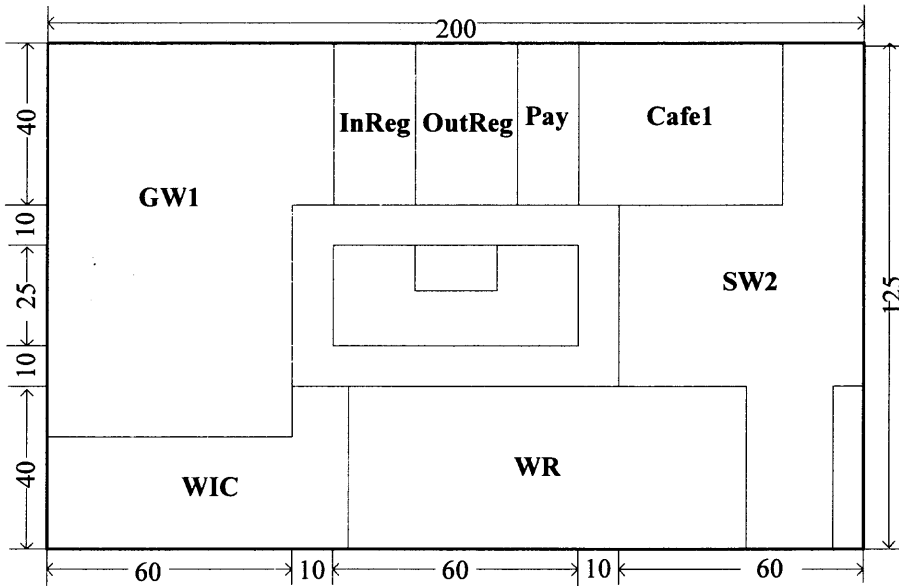

Figure 4.15 Floor2 layout for simulation strategy3.

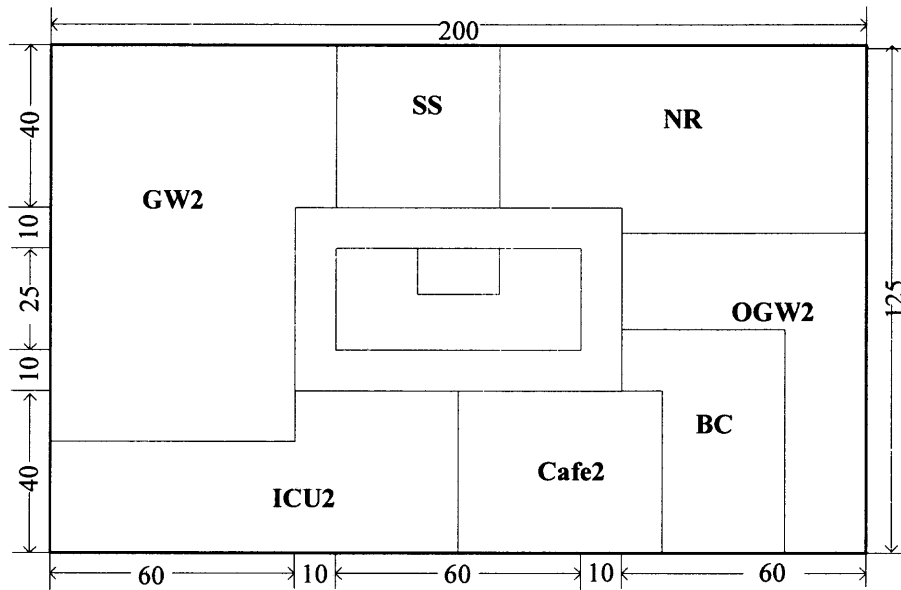

Figure 4.16 Floor3 layout for simulation strategy3.

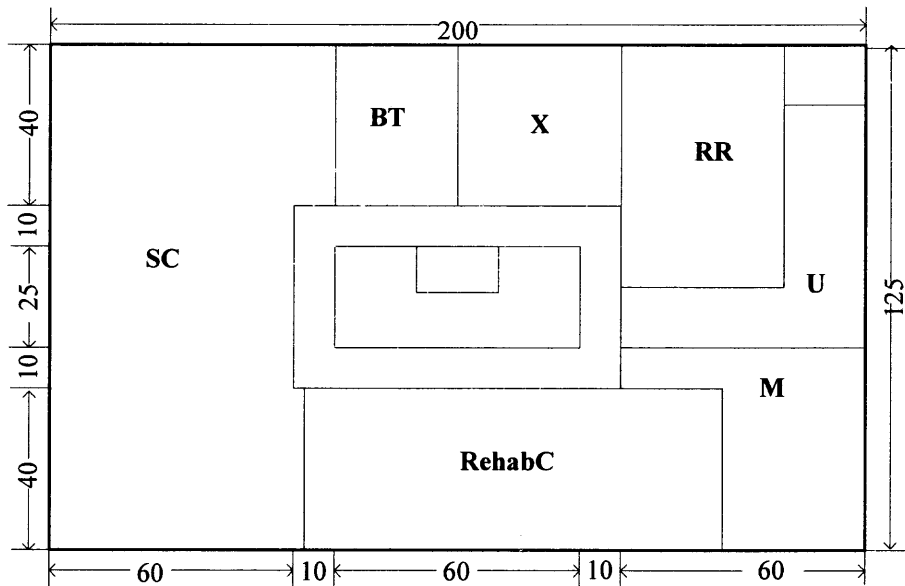

Figure 4.17 Floor4 layout for simulation strategy3.

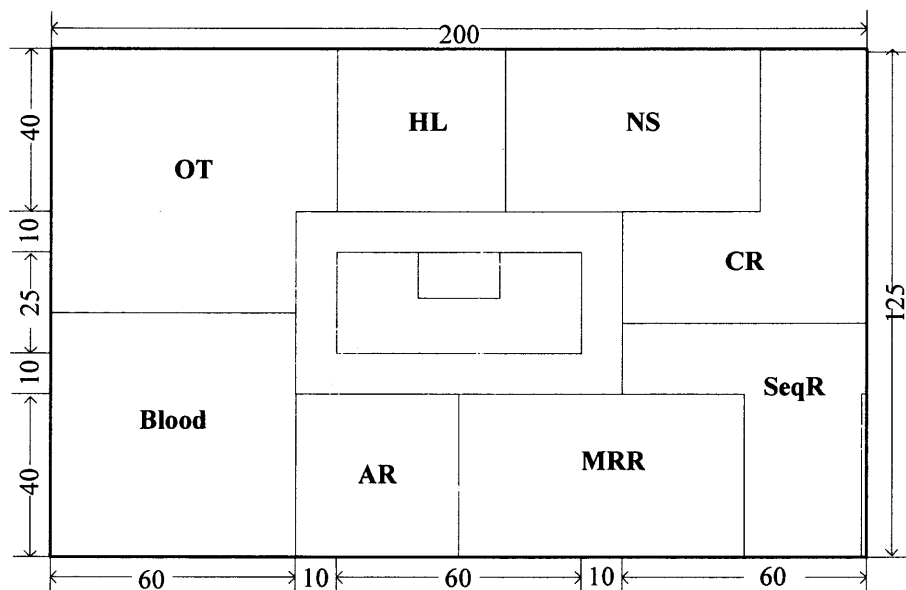

Figure 4.18 Floor5 layout for simulation strategy3.

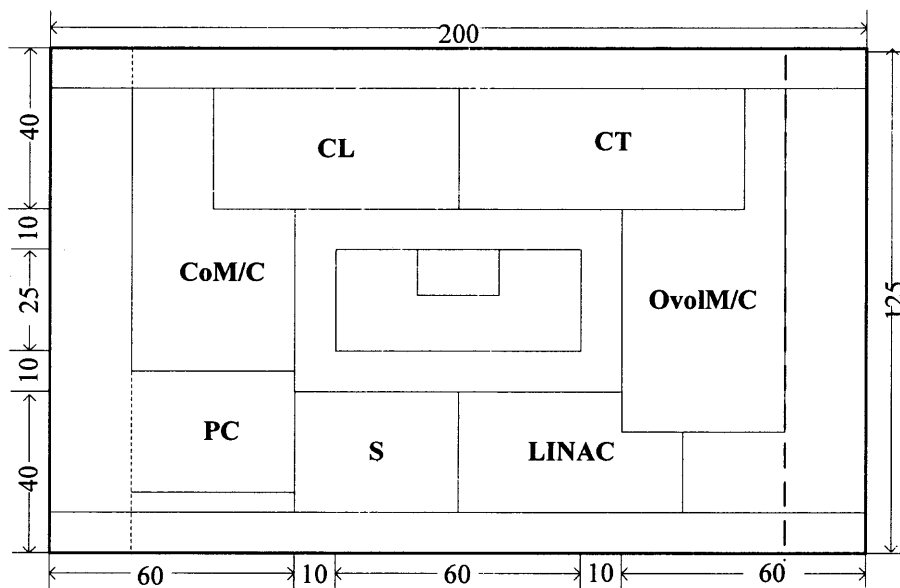

Figure 4.19 Floor6 layout for simulation strategy3.

CHAPTER 5

SUMMARY

A model for multi-floor facility layouts is generated to solve important layout issues arising within a hospital and to facilitate the efficient movement of entities between departments. The model computes the movement cost resulting from the optimal arrangement of departments.

Effect of Layout Strategies on Movement Cost

Numerous simulations are run to observe the effect of department rearrangements on movement cost. This rearrangement is achieved by designing certain layout strategies. Figure 5.1 shows the effect of different proposed layout strategies on the movement cost. The movement costs obtained for each layout strategy and the percentage reduction in the movement cost are shown in Table 5.1.

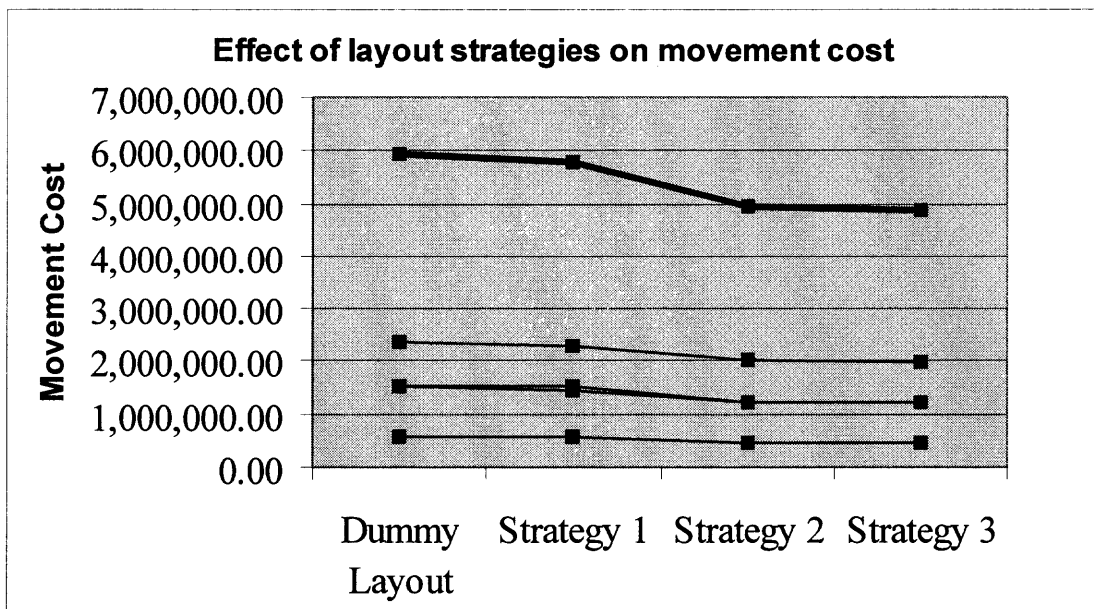

Figure 5.1 Effect of layout strategies on movement cost.

Table 5.1 Movement Cost Variation Analysis

Travel Entities	Movement Cost				Reduction in Movement Cost Between		
	Sample Layout	Layout Strategy1	Layout Strategy2	Layout Strategy3	Sample & Strategy1	Strategy1 & Strategy2	Strategy2 & Strategy3
Patients	1,533,804	1,505,904	1,228,721	1,226,505	1.82%	18.41%	0.18%
Doctors	1,503,259	1,446,936	1,218,799	1,212,428	3.75%	15.77%	0.52%
Medical Staff	2,343,224	2,270,429	2,033,001	1,977,717	3.11%	10.46%	2.76%
Non-Medical Staff	562,571	553,076	463,312	442,098	1.69%	16.23%	4.79%
Total	5,942,860	5,776,347	4,943,834	4,858,749	2.80%	14.41%	1.72%

The large flow of travel entities in the vertical direction to different floors necessitates monitoring the flow and arranging the departments accordingly. Thus in strategy 1 of Section 4.1, departments generating high traffic going to different floors were brought closer to the elevator so that the vertical movement of travel entities was reduced. The movement cost is reduced as distance traveled is reduced. Simulation results show a total cost reduction of 2.80%. The movement cost reduction for different travel entities is shown in Table 5.1.

In hospitals, there is a large traffic flow in the horizontal direction also. Hence, it is necessary to arrange the departments by monitoring both the vertical and horizontal flow of traffic. This is achieved in strategy 2 of Section 4.2. In this layout strategy, in addition to the considerations of strategy 1, two departments are placed adjacent to or further from each other depending on the degree of desired closeness, which in turn is a function of the travel frequency between the departments. The optimal number of floors required for arranging all the departments is also determined. Simulation results show a further reduction in movement cost of 14.41% over the cost of strategy 1.

There is a very large flow of travel entities in and out of some departments. In strategy 3 some departments that have large areas and heavy traffic are split on two floors. The principles of closeness to the elevator and interaction between departments are the same as those used in the previous strategy. Simulation results show a further reduction in movement cost of 1.72% over the cost of strategy 2.

Suggestions for Further Research

Several simplifying assumptions were made when the models were developed. Capital costs and intradepartmental movements were not considered. Since computations were made using Microsoft Excel, rectilinear distances were used between any two departments and the flow of travel entities was assumed to follow that path. Future research efforts may incorporate model enhancements that can make the final results more accurate and more realistic by considering facility layout aspects that were excluded from the formulation presented here.

The models' accuracy will be enhanced significantly, if actual paths between departments are considered. Instead of considering only the rectilinear distance, paths could trace the movements as they actually occur going through doors and following corridor contours.

The inclusion of capital costs in the evaluation of alternative layouts will make the comparison of the alternatives in terms of cost more meaningful. Splitting departments may reduce the movement cost, but that cost reduction has to be traded off with cost increases necessitated from the possible duplication of equipment. The inclusion of capital costs can also answer questions about trade offs between the footprint and height of the entire facility.

The inclusion of intradepartmental movements, accurate baseline movement costs for each entity, and the detailed space and equipment needs of each department can also be used on future models, not only to increase their accuracy, but also to incorporate micro layouts.

Finally, it was acknowledged that special safety and ergonomics considerations may exist, but they were not considered explicitly in the models. Including such concerns in future models will make them more realistic and particularly since the layouts considered here are associated with hospitals where safety and ergonomics considerations are of great importance.

APPENDIX A

CALCULATION OF OPTIMAL NUMBER OF FLOORS

The arrangement of departments on optimal number of floors is desirable while building a new hospital as it results in lesser distance required to be traveled. The derivation proposes a formula for obtaining the number of floors, with all the necessary areas as the known parameters.

Notations:

- f : Number of floors
- A_i : Total area occupied by the departments
- A_d : Area occupied by the departments on each floor
- A_e : Elevator and waiting areas
- A_p : Passage area
- A_{th} : Theoretical area of the floor
- A_{prac} : Practical or calculated area of the floor
- A_{bth} : Theoretical area of the hospital building
- A_{bprac} : Practical or calculated area of the hospital building

Derivation:

Theoretical area of the hospital building must be greater than or equal to the practical or calculated area.

$$A_{bth} \geq A_{bprac}$$

Now,

$$A_{bth} = f \times A_{th}$$

and

$$A_{bprac} = f \times A_{prac}$$

We have,

$$A_{prac} = A_d + A_e + A_p$$

$$\therefore f \times A_{th} \geq f \times A_{prac}$$

$$\Rightarrow f \times A_{th} \geq f \times (A_d + A_e + A_p)$$

$$\therefore f \times A_{th} \geq f \times A_d + f \times (A_e + A_p)$$

$$\therefore f \times A_{th} \geq A_i + f \times (A_e + A_p)$$

$$\therefore f \geq \frac{A_i}{A_{th} - (A_e + A_p)}$$

For the mathematical model of hospital facility layout design illustrated in the example,

Total area of departments	(A_i)	= 118100
Theoretical area of the floor	(A_{th})	= 25000
Elevator and lodge area	(A_e)	= 1500
Passage area	(A_p)	= 2100

$$\therefore f \geq \frac{118100}{25000 - (1500 + 2100)}$$

$$\therefore f \geq 5.5 \approx 6$$

REFERENCES

1. Tompkins J., White J., Bozer W., Tanchoco J. 2003, Facilities Planning, 3rd edition. John Wiley & Sons Inc, New York, USA.
2. Moore J. 1970, Plant Layout and Design, 4th edition. The Macmillan Company, New York.
3. Francis R., White J. 1974, Facility Layout and Location: An Analytical Approach, Englewood Cliffs: Prentice Hall.
4. Mecklenburg J. 1985, Process Plant Layout, Institute of Chemical Engineers, London.
5. Kusiak A., Heragu S. 1987, The facility layout problem, European Journal of Operational Research, vol. 29, 229-251.
6. Meller R, Gau K 1996, The facility layout problem: recent and emerging trends and perspectives, Journal of Manufacturing Systems, vol.15, 351-366.
7. Barbosa-Povoa A., Mateus R., Novais A. 2001, Optimal two-dimensional layout of industrial facilities, International Journal of Production Research vol. 39, No. 12, 2567-2593.
8. Koopmans T., Beckham M. 1957, Assignment problems and the location of economic activities, Econometrica, vol. 25, 53-76.
9. Lawler E. 1963, The quadratic assignment problem. Management Science, vol. 9, 586-599.
10. Kettani O., Muhittin O. 1993, Reformulating quadratic assignment problems for efficient optimization. IIE Transactions, vol. 25, 97-107.
11. Skorin-Kapov J. 1994, Extensions of the tabu search adaptation to the quadratic assignment problem. Computers and Operations Research, vol. 21, 855-865.
12. Conway D., Venkataraman M. 1994, Genetic search and the dynamic facility layout problem. Computers and Operations Research, vol. 21, 955-960.
13. Tate D., Smith A. 1995, A genetic approach to the quadratic assignment problem. Computers and Operation Research, vol. 22, 73-83.
14. Bland J., Dawson G. 1994, Large-scale layout facilities using a heuristic hybrid approach algorithm. Applied Mathematical Modeling, vol. 18, 500-503.

15. Hassan M., and Hogg G. 1987, A review of graph theory applications to the facilities layout problem. *Omega*, vol. 15, 291-300.
16. Montreuil B. 1990, A modeling framework for integrating layout design and flow network design. *Proceedings of the Material Handling Research Colloquium*, Hebron, KY, 43-58.
17. Kusiak A., Heragu S. 1987, The facility layout problem, *European Journal of Operational Research*, vol. 29, 229-251.
18. Lacksonen T. 1997, Pre-processing for static and dynamic facility layout problems. *International Journal of Production Research*, vol. 35, 1095-1106.
19. Moseley L. 1963, A rational design theory for planning buildings based on the analysis and solution of circulation problems. *The Architects' Journal*, 525-537.
20. Neghabat F. 1974, An efficient equipment layout algorithm. *Operations Research*, vol. 22, 622-628.
21. Cinar U. 1975, Facilities planning: a systems analysis and space allocation approach. *Spatial Synthesis in Computer-aided Building Design* (New York: Wiley), 19-40.
22. Johnson R. 1982, SPACECRAFT for multi-floor planning. *Management Science*, vol. 28, 407-417.
23. Liggett R., Mitchell W. 1981, Optimal space planning in practice, *Computer-Aided Design*, vol. 13, 277-288.
24. Foulds L., Giffin J 1984, A graph theoretic heuristic for multi-floor building layout, *Annual International Industrial Engineering Conference Proceedings*, Institute of Industrial Engineers, 202-205.
25. Kaku B., Thompson G., Baybars I. 1988, A heuristic method for the multistory layout problem, *European Journal of Operational Research*, vol. 37, 384-397.
26. Lath S. 1989, The multidimensional facility layout problem: a hierarchical model and solution method, PhD Dissertation, Engineering Sciences, Rensselaer Polytechnic Institute.
27. Donaghey C., Pire V. 1991, Solving the facility layout problem with BLOCPLAN, *Factory Automation and Information Management: Proceedings of a Conference held at the University of Limerick, Limerick, Ireland*, 649-658.

28. Bozer Y., Meller R., Erlebacher S. 1994, An improvement-type layout algorithm or single and multi-floor facilities, *Management Science*, vol. 40, 918-932.
29. Meller R., Bozer Y. 1996, A new simulated annealing algorithm for the facility layout problem, *International Journal of Production Research*, vol. 34, 1675-1692.
30. Meller R., Bozer Y. 1997, Alternative approaches to solve the multi-floor facility layout problem, *Journal of Manufacturing Systems*, vol. 16, 192-203.
31. Kochhar J., Heragu S. 1998, MULTI-HOPE: a tool for multiple floor layout problems, *International Journal of Production Research*, vol. 38, No. 12, 3421-3435.
32. Abdinnour-Helm S., Hadley S. 2000, Tabu Search based heuristics for multi-floor facility layout, *International Journal of Production Research*, vol. 38, No. 2, 365-383.
33. Hahn P., Krarup J. 2001, A hospital facility layout problem finally solved, *Klinikum Regensburg Hospital, Germany*.
34. Anjos M., Vannelli A. 2002, A new mathematical programming framework for facility layout design, *University of Waterloo technical report, Ontario, Canada*.
35. Armour G., Buffa, E. 1963, A heuristic algorithm and simulation approach to relative location of facilities, *Management Science*, vol. 9, 294-309.
36. Resende M., Li Y., Pardalos P. 1996, A Greedy Randomized Adaptive Search Procedure (GRASP) for the Quadratic Assignment Problem (QAP), *Transactions on Mathematical Software*, vol. 22, No. 1, 104-118.
37. Nahmias S. 1997, *Production and Operations Analysis*, 3rd edition. Irwin/McGraw-Hill, Singapore.
38. <http://www.mathematik.uni-kl.de/~wwwopt/research/health.html> [April 04, 2003]
39. Dooyeweerd R., Schuring R. 2002, *Applying the process perspective to the design of hospital facilities*, Department of Health Care Management, Netherlands.
40. Todd Wheeler, Faia E 1971, *Hospital Modernization and Expansion*, McGraw Hill Book Company, USA.
41. <http://www.tefen.com/industries.asp?pageInstanceId=6#top> [April 04, 2003]
42. <http://persoweb.francenet.fr/~mondor/schwab.htm> [June 25, 2003]